



METROLOGIC INSTRUMENTS, INC.
MS9524/44 VoyagerPDF® Series
Single-Line Hand Held Laser Scanner
Installation and User's Guide



Copyright

© 2006 by Metrologic Instruments, Inc. All rights reserved. No part of this work may be reproduced, transmitted, or stored in any form or by any means without prior written consent, except by reviewer, who may quote brief passages in a review, or provided for in the Copyright Act of 1976.

Products and brand names mentioned in this document are trademarks of their respective companies.

TABLE OF CONTENTS

Introduction.....	1
Scanner and Accessories.....	2
Installing the Scanner to the Host System	
RS232, Laser Emulation, and Light Pen	4
IBM 46xx and OCIA.....	5
Keyboard Wedge.....	6
Stand-Alone Keyboard	7
Integrated USB	
Full Speed	8
Low Speed	8
The PowerLink Cable	
Disconnecting.....	9
Connecting	9
How to Scan	
Three Modes of Operation.....	10
How to Scan with CodeGate® - MS9544	10
How to Scan in the Manual Activation Mode	10
How to Scan PDF Bar Codes	11
Stand.....	12
Kits	12
Assembly.....	13
Scanner Parts.....	16
Indicators	
Audible	17
Visual	18
Failure Modes.....	19
Configuration Modes	20

TABLE OF CONTENTS

Upgrading the Flash ROM Firmware	23
Labels	24
Maintenance	24
Depth of Field	
Minimum Bar Code Element Width	25
PDF417 Minimum Bar Code Element Width	26
IR Activation	27
Applications and Protocols	28
Troubleshooting Guide	29
RS232 Demonstration Program	32
Default Settings	35
Scanner and Cable Terminations	
Scanner Pinout Connections	40
Cable Connector Configurations	42
Limited Warranty	44
Laser and Product Safety	
Notices	45
Cautions	47
Patents	48
Index	49

INTRODUCTION

Metrologic's VoyagerPDF series is a group of single-line, hand-held, laser bar code scanners that have the ability to decode 2D codes such as PDF417, PDF417 truncated, micro PDF, macro PDF and RSS-14 composite bar code symbologies. Some additional key product features include:

- Auto-trigger operation and auto stand detect
- CodeGate data transmission technology (MS9544 only)
- Flash - upgradeable firmware
- 180 scans per second
- Detachable user-replaceable cables
- Easy configuration with MetroSelect® barcodes and MetroSet® 2 Windows® compatible software
- OPOS and JPOS system compatibility
- Support for common interfaces including USB (see chart below)

There are two models available, the MS9524 and the MS9544 with CodeGate®. The MS9524 is packed with all of the same features as the MS9544, with the exception of CodeGate.

The MS9544 includes Metrologic's patented auto trigger and CodeGate button feature. When a bar code is placed in the scanner's IR range the auto trigger activates the laser allowing the user to easily align the visible laser line over the bar code selected for scanning. Then just press the CodeGate button and the data is transmitted to the host system.

Since scanning PDF codes requires multiple scans, a separate configurable CodeGate feature has been added. With PDF CodeGate disabled, PDF codes can be decoded and transmitted automatically without compromising the versatility achieved with CodeGate. An in-stand/out-of-stand sensor automatically de-activates CodeGate when the scanner is placed in the stand.

VOYAGERPDF	VOYAGERPDF WITH CODEGATE	INTERFACE
MS9524 – 00	MS9544 – 00	Laser Emulation*, RS232 Transmit/Receive*
MS9524 – 9	MS9544 – 9	OCIA*
MS9524 – 11	MS9544 – 11	IBM 468X/469X*, RS232-TXD, RXD, RTS, CTS
MS9524 – 14	MS9544 – 14	RS232 - TXD, RXD, RTS, CTS, DTR, DSR
MS9524 – 38	MS9544 – 38	Low Speed USB, Serial Emulation Mode or Keyboard Emulation Mode
MS9524 – 40	MS9544 – 40	Full-speed USB
MS9524 – 41	MS9544 – 41	RS232 / Light Pen Emulation*
MS9524 – 47	MS9544 – 47	Keyboard Wedge, Stand-Alone Keyboard and RS232 Transmit/Receive

* PDF bar codes are transmitted as Code 39 for these interfaces. Acceptance on host side is dependant on host's ability to handle large amounts of data.

SCANNER AND ACCESSORIES

BASIC KIT	
Part #	Description
MS9524 x or MS9544 x	VoyagerPDF Series Scanner
00-02544	MetroSelect® Single-Line Configuration Guide*
00-02989	MS9524/44 VoyagerPDF Series Installation and User's Guide*

* Available on the Metrologic website - www.metrologic.com

OPTIONAL ACCESSORIES	
Part #	Description
AC to DC Power Transformer- Regulated 5.2VDC @ 650 mA output.	
45-45593	120V United States
45-45591	220V-240V Continental European
45-45592	220V-240V United Kingdom
46-46803	220V-240V Australia
46-46931	220V-240V China
53-53000 x -3	RS232 PowerLink Cable with Built in Power Jack 2.7 m (9 ft.) <i>coiled</i> cord, long strain relief, black
54-54000 x -3	RS232 PowerLink Cable with Built in Power Jack 2.1 m (7 ft.) <i>straight</i> cord, short strain relief, black
53-53002 x -3	Keyboard Wedge PowerLink Cable with Adapter Cable 2.7 m (9 ft.) <i>coiled</i> cord, long strain relief, black
53-53020 x -3	Stand-Alone Keyboard Wedge PowerLink Cable 2.7 m (9 ft.) <i>coiled</i> cord, long strain relief, black

Other items may be ordered for the specific protocol being used. To order additional items, contact the dealer, distributor or call Metrologic's Customer Service Department at 1-800-ID-METRO or 1-800-436-3876.

SCANNER AND ACCESSORIES

OPTIONAL ACCESSORIES	
Part #	Description
53-53213.x-N-3	USB Full Speed Cable, Locking Plus-Power™ Type A 2.7 m (9 ft.) coiled cord, long strain relief
53-53214.x-N-3	USB Full Speed Cable, Locking Plus-Power™ Type A 4.5 m (15 ft.) coiled cord, long strain relief, black  <i>This cable is for use with full speed USB (-40) units. Do not use this cable with low speed USB (-38) units.</i>
53-53235.x-N-3	USB Low Speed Communication Cable, Type A (Non-Locking) Connector 2.7 m (9 ft.) coiled cord, long strain relief, black
MVC**	Metrologic Voltage Converter Cable, $\pm 12\text{VDC}$ to $+5.2\text{VDC}$ for IBM and OCIA applications
** <i>Contact a Metrologic customer service representative for additional information on the MVC converter cable series and the host connections available.</i>	
46-46128	Free-Standing Stand with Accessories
46-46351	Hard Mount Accessory Kit <i>(used with kit #46-46128)</i>
46-46433 OR 46-46508	Wall Mount Hanger Accessory Kit

Other items may be ordered for the specific protocol being used. To order additional items, contact the dealer, distributor or call Metrologic's Customer Service Department at 1-800-ID-METRO or 1-800-436-3876.

INSTALLING THE SCANNER TO THE HOST SYSTEM

RS232, Laser Emulation, and Light Pen (MS9524-14/00/41 or MS9544-14/00/41)

1. Turn off the host system.
2. Connect the 10-pin RJ45 male connector into the jack on the VoyagerPDF. You will hear a 'click' when the connection is made.
3. Connect the L-shaped plug of the power supply into the power jack on the PowerLink cable.
4. Make sure the AC input requirements of the power supply match the AC outlet. Connect the power supply into an AC outlet. The outlet should be near the equipment and easily accessible.
5. Connect the PowerLink cable to the proper port on the host system.
6. Turn on the host system.

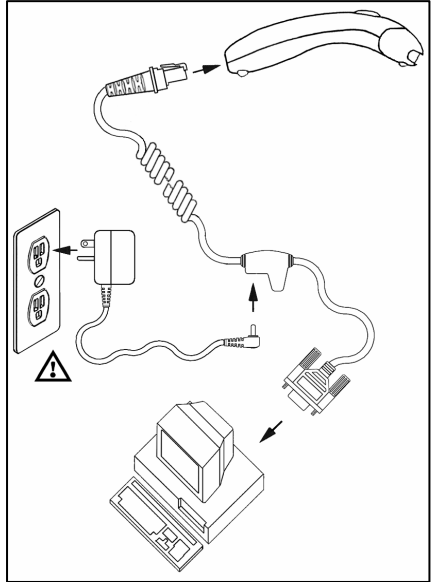

Figure 1



Plugging the scanner into a port on the host system does not guarantee that scanned information will be communicated properly to the host system. Please refer to the MetroSelect Single-Line Configuration Guide or MetroSet2's help files for instructions on changing the scanner's factory default configuration. The scanner and host system must use the same communication protocols.



All MS9524-00/MS9544-00 scanners leave the factory with the Laser Emulation Mode enabled. If you recall defaults while re-configuring the scanner the Laser Emulation Mode will no longer be enabled. Refer to the *MS9520/9540-00 Laser Emulation Mode* section of the MetroSelect Single-Line Configuration Guide for information on enabling the *Laser Emulation Mode*.

Caution:

To maintain compliance with applicable standards, all circuits connected to the scanner must meet the requirements for SELV (Safety Extra Low Voltage) according to EN/IEC 60950-1.



To maintain compliance with standard CSA-C22.2 No. 60950-1/UL 60950-1 and norm EN/IEC 60950-1, the power source should meet applicable performance requirements for a limited power source.

INSTALLING THE SCANNER TO THE HOST SYSTEM

IBM 46xx and OCIA (MS9524-11/9 and MS9544-11/9)

1. Turn off the host system.
2. Plug the male 10-pin RJ45 end of the MVC cable into the 10-pin socket on the scanner. You will hear a 'click' when the connection is made.
3. Connect the other end of the MVC cable to the host device.
4. Turn on the host system.

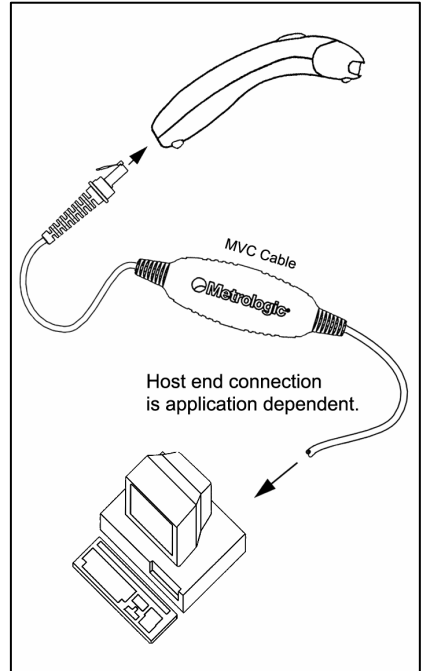

Figure 2



Plugging the scanner into a port on the host system does not guarantee that scanned information will be communicated properly to the host system. Please refer to the MetroSelect Single-Line Configuration Guide or MetroSet2's help files for instructions on changing the scanner's factory default configuration. The scanner and host system must use the same communication protocols.

Caution:

To maintain compliance with applicable standards, all circuits connected to the scanner must meet the requirements for SELV (Safety Extra Low Voltage) according to EN/IEC 60950-1.



To maintain compliance with standard CSA-C22.2 No. 60950-1/UL 60950-1 and norm EN/IEC 60950-1, the power source should meet applicable performance requirements for a limited power source.

INSTALLING THE SCANNER TO THE HOST SYSTEM

Keyboard Wedge (MS9524-47 and MS9544-47)

1. Turn off the PC.
2. Connect the 10-pin RJ45 male connector into the jack on the VoyagerPDF. You will hear a 'click' when the connection is made.
3. Connect the L-shaped plug of the power supply into the power jack on the PowerLink cable.
4. Make sure the AC input requirements of the power supply match the AC outlet. Connect the power supply into an AC outlet. The outlet should be near the equipment and easily accessible.
5. Disconnect the keyboard from the PC.
6. Connect the PowerLink cable to the keyboard and the PC's keyboard port. If necessary use the supplied adapter cable (5-pin male DIN to 6-pin female DIN adapter).
7. Power up the PC.

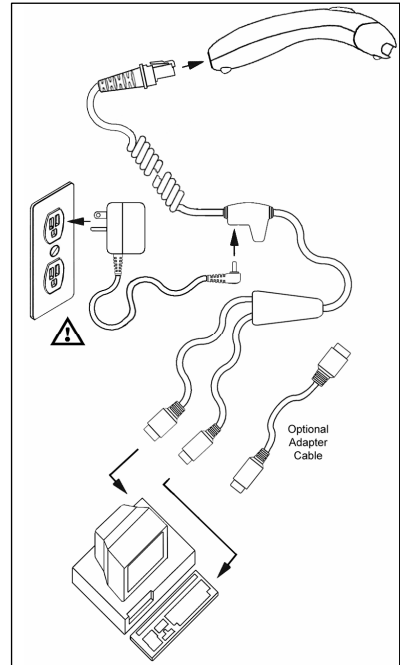

Figure 3



Plugging the scanner into a port on the host system does not guarantee that scanned information will be communicated properly to the host system. Please refer to the MetroSelect Single-Line Configuration Guide or MetroSet2's help files for instructions on changing the scanner's factory default configuration. The scanner and host system must use the same communication protocols.



Caution:

To maintain compliance with applicable standards, all circuits connected to the scanner must meet the requirements for SELV (Safety Extra Low Voltage) according to EN/IEC 60950-1.

To maintain compliance with standard CSA-C22.2 No. 60950-1/UL 60950-1 and norm EN/IEC 60950-1, the power source should meet applicable performance requirements for a limited power source.

INSTALLING THE SCANNER TO THE HOST SYSTEM

Stand-Alone Keyboard (MS9524-47 or MS9544-47)

1. Turn off the host system.
2. Connect the 10-pin RJ45 male connector into the jack on the VoyagerPDF. You will hear a 'click' when the connection is made.
3. Connect the L-shaped plug of the power supply into the power jack on the PowerLink cable.
4. Make sure the AC input requirements of the power supply match the AC outlet. Connect the power supply into an AC outlet. The outlet should be near the equipment and easily accessible.
5. Connect the PowerLink cable to the keyboard port on the host system.
6. Turn on the host system.

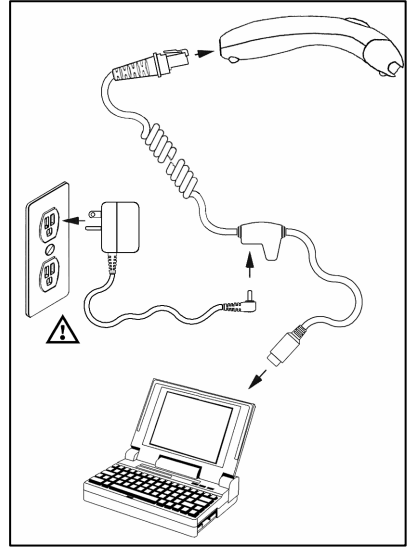

Figure 4



Plugging the scanner into a port on the host system does not guarantee that scanned information will be communicated properly to the host system. Please refer to the MetroSelect Single-Line Configuration Guide or MetroSet2's help files for instructions on changing the scanner's factory default configuration. The scanner and host system must use the same communication protocols.

Caution:

To maintain compliance with applicable standards, all circuits connected to the scanner must meet the requirements for SELV (Safety Extra Low Voltage) according to EN/IEC 60950-1.



To maintain compliance with standard CSA-C22.2 No. 60950-1/UL 60950-1 and norm EN/IEC 60950-1, the power source should meet applicable performance requirements for a limited power source.

INSTALLING THE SCANNER TO THE HOST SYSTEM

Integrated USB: Full Speed (MS9524-40 and MS9544-40) Low Speed HID (MS9524-38 and MS9544-38)

1. Turn off the host system.
2. Connect the 10-pin RJ45 male connector of the USB cable into the jack on the VoyagerPDF. You will hear a 'click' when the connection is made.
3. Connect the other end of the USB cable to the host USB port.
4. Turn on the host system.

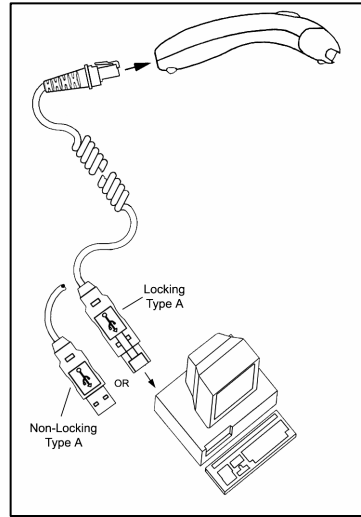

Figure 5



As a default, the MS9524-38/MS9544-38 leaves the factory with USB Keyboard Emulation Mode enabled.

For information on configuring the MS9524-38/MS9544-38 for USB Serial Emulation Mode, please refer to the USB section of the MetroSelect Single-Line Configuration Guide (MLPN 00-02544).



Plugging the scanner into a port on the host system does not guarantee that scanned information will be communicated properly to the host system. Please refer to the MetroSelect Single-Line Configuration Guide or MetroSet2's help files for instructions on changing the scanner's factory default configuration. The scanner and host system must use the same communication protocols.



Caution:

To maintain compliance with applicable standards, all circuits connected to the scanner must meet the requirements for SELV (Safety Extra Low Voltage) according to EN/IEC 60950-1.

To maintain compliance with standard CSA-C22.2 No. 60950-1/UL 60950-1 and norm EN/IEC 60950-1, the power source should meet applicable performance requirements for a limited power source.

THE POWERLINK CABLE

Disconnecting

Before removing the cable from the scanner, Metrologic recommends that the power on the host system is off and the power supply has been disconnected from the PowerLink cable.

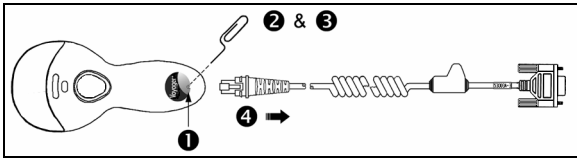

Figure 6

1. Locate the small 'pin-hole' on the top of the unit near the bottom of the Voyager logo.
2. Bend an ordinary paperclip into the shape shown above.
3. Insert the paperclip (or other small metallic pin) into the small 'pin-hole'.
4. You will here a faint 'click'. Pull gently on the strain-relief of the PowerLink cable and it will slide out of the scanner.

Connecting

Important: If the PowerLink cable is not fully 'latched' the unit can power intermittently.

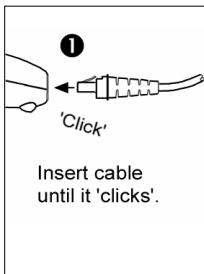

Figure 7

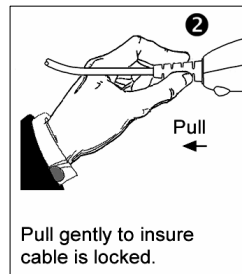

Figure 8

HOW TO SCAN

Three Modes of Operation

Auto Trigger, In-Stand

- Auto-triggers while in the stand
- Bar code is automatically decoded and transmitted

CodeGate, Out-of-Stand

- CodeGate activates when removed from the stand
- Bar code data is transmitted when the button is pressed

Manual Activation Mode*, Out-of-Stand

- Button activates laser
- Bar code data is scanned and transmitted while button is held down

How to Use CodeGate (MS9544) and the Manual Activation Mode

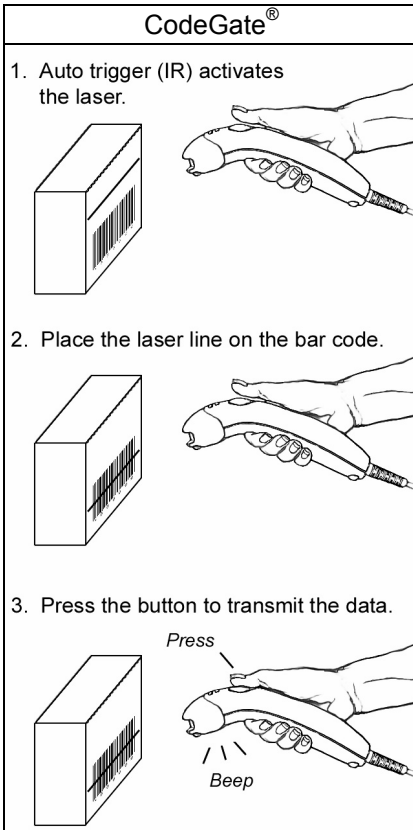

Figure 9.

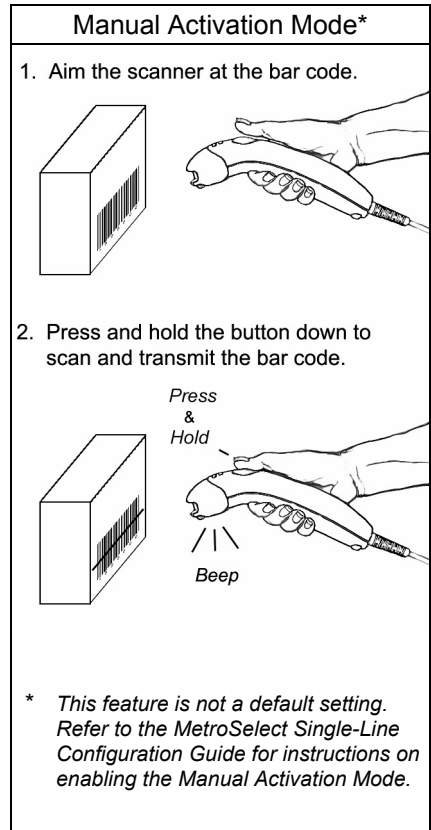

Figure 10.

HOW TO SCAN

Operator Note: PDF-CodeGate is disabled (by default) in all MS9544 VoyagerPDF units.



Figure 11.

1. The auto trigger activates the laser when the bar code is placed in the scanner's IR range.

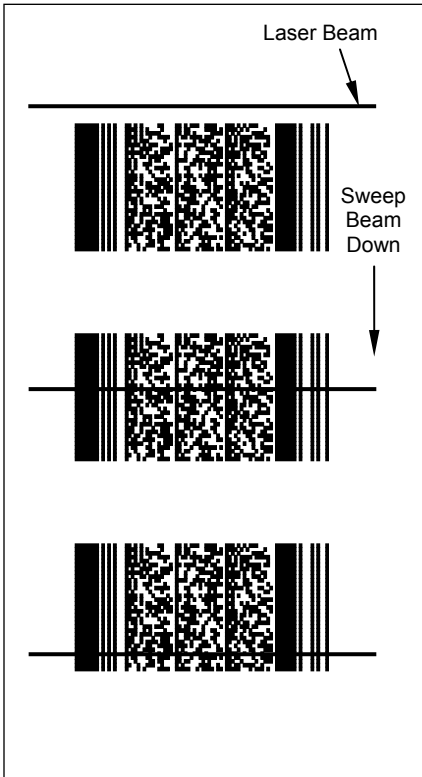

Figure 12.

2. Position the laser line at the top of the code then sweep the beam over and down to the base of the code. If needed, re-sweep the entire code, up and down. As segments of the code are scanned, an audible indicator will sound (default).



Operator Note:

Best scanning results are accomplished with a uniform sweep speed.

3. Once the entire code has been scanned and decoded, the data is transmitted to the host. Transmission is accompanied by the white LED flashing and the beep sounding.

STAND

Free Standing Kits #46-46128

- a. Stand (MLPN 36-00454).....Qty 1
- b. Apron (MLPN 50-50440).....Qty 1
- c. Screw, M3 x 6 mm (MLPN 18-18670).....Qty 2
- d. Washer, #5 x .5 OD (MLPN 18-18671)Qty 2
- e. Stand Anchor (MLPN 50-50449)Qty 1
- f. M3 x 20 mm Set Screw (MLPN 18-18672).Qty 1

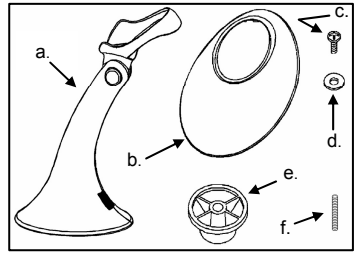

Figure 13.

Optional Hard Mount Accessory Kit #46-46351

This kit, used in conjunction with the stand kit (#46-46128), can be used to bolt/hard mount the MS9500 to the countertop.

- a. Screw, #8 Round Head (MLPN 18-18057)Qty 4
- b. Base (MLPN 36-36080)Qty 1

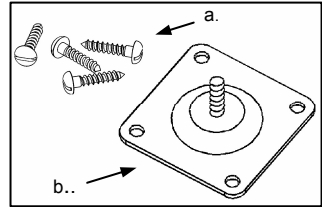

Figure 16.

Optional Wall Mount Hanger Accessory Kit #46-46433

- a. Screw #8 Round Head (MLPN 18-18057)Qty.2
- b. Wall Mount Hanger (MLPN 36-00611).....Qty.1

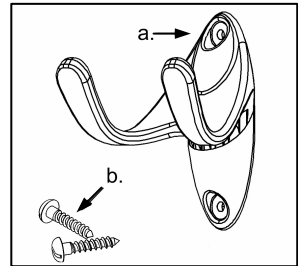

Figure 16.

Optional Wall Mount Hanger Kit #46-46508

- a. Wall Mount Hanger (MLPN 36-00611).....Qty. 1
- b. Wall Mount Base (MLPN 36-00812)Qty. 1
- c. 4.8 x 13 mm, Self Tapping ScrewQty. 2 (MLPN 18-18233)
- d. Double-Sided Adhesive TapeQty. 1 (MLPN 36-00821)
- e. #8 Wood Screw (MLPN 18-18057)Qty. 2

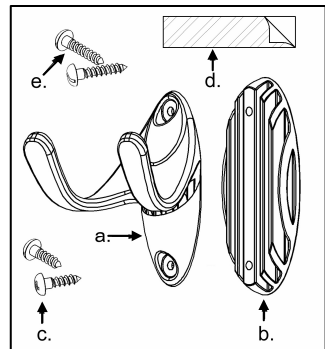

Figure 16.

STAND

There are two options for assembling the stand. The first option allows the stand to be self-supporting and moved freely or placed anywhere on the countertop. The second option is used if the stand will be bolted/hard-mounted to the countertop.

Stand Option 1: Self-Supported for use with Kit #46-46128

Step 1

Slide the apron (MLPN 50-50440) over the stand (MLPN 36-00454).

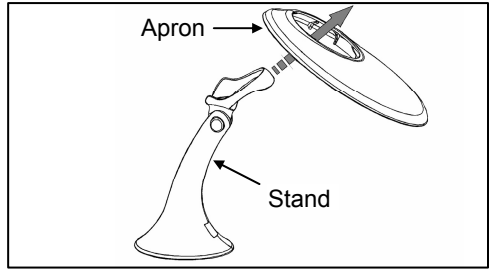

Figure 17.

Step 2

Position the stand so it sits under the tab on the apron. Then secure the apron to the stand using the M3 x 6 mm screws (MLPN 18-18670) and the #5 washers (MLPN 18-18671) provided.

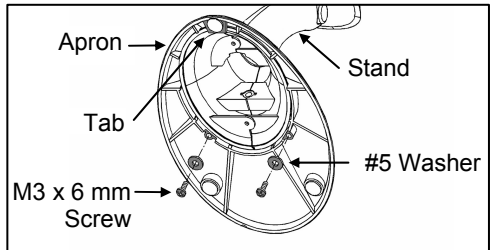

Figure 18.

Stand Option 2: Hard-Mounted to Countertop for use with Kit #46-46351

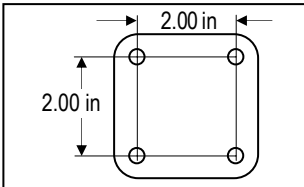

Figure 19.

Step 1

Drill four #39 holes in the countertop.

Step 2

Secure the base (MLPN 36-36080) to the countertop with the four #8 wood screws (MLPN 18-18057) provided.

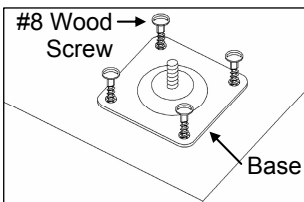

Figure 20.

STAND

Stand Option 2: Hard-mounted to countertop (*continued*) For use with kits #46-46128, #46-46351 and MS951 Stand Replacements

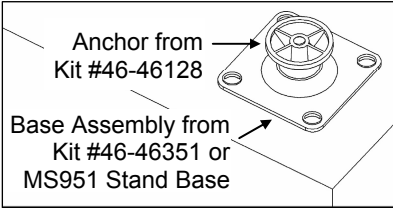

Figure 21.

Step 3

Screw the stand anchor (*MLPN 50-50449*) onto the base assembly until it sits flush.

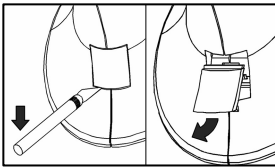

Figure 22.

Step 4

Remove the logo plate on the stand by gently using an *Exacto* knife to release the plate hook.

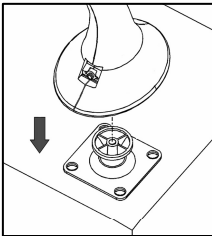

Figure 23.

Step 5

Position the stand over the base assembly.

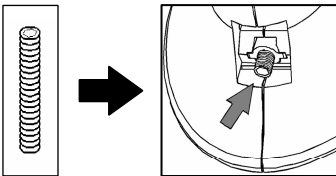

Figure 24.

Step 6

Secure the stand to the base assembly by installing and tightening the M3 set screw (*MLPN 18-18672*) under the logo plate as shown.

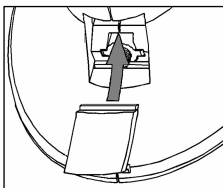

Figure 25.

Step 7

Snap the logo plate back into place.

STAND

Wall Mount, Option 1:

For Kit #46-46433 or
Kit #46-46508

Step 1:

Drill two #39 pilot holes 3.00" apart.

Step 2:

Attach the *Wall Mount Hanger* to the wall with the two #8 wood screws provided.

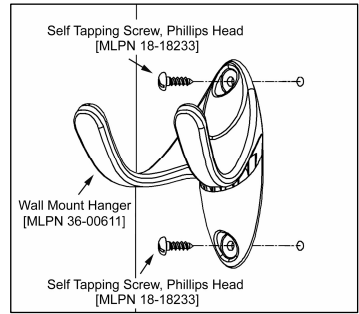

Figure 26.

Wall Mount, Option 2:

Kit #46-46508

Step 1:

Attach the *Wall Mount Base* to the *Wall Mount Hanger* with the two 4.8 x 13 mm self-tapping screws.

Step 2:

Remove one side of the protective backing from the double-sided adhesive tape.

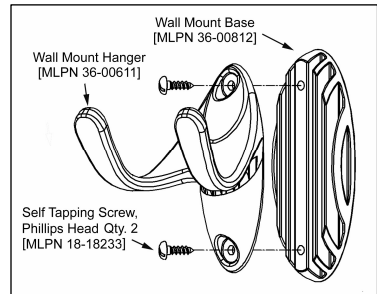

Figure 27.

Step 3:

Attach the tape to the back of the *Wall Mount Hanger* as shown.

Step 4:

Remove the protective backing from the double-sided adhesive tape and apply hook to the wall.

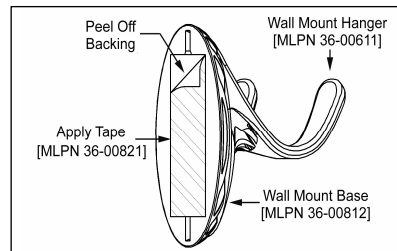
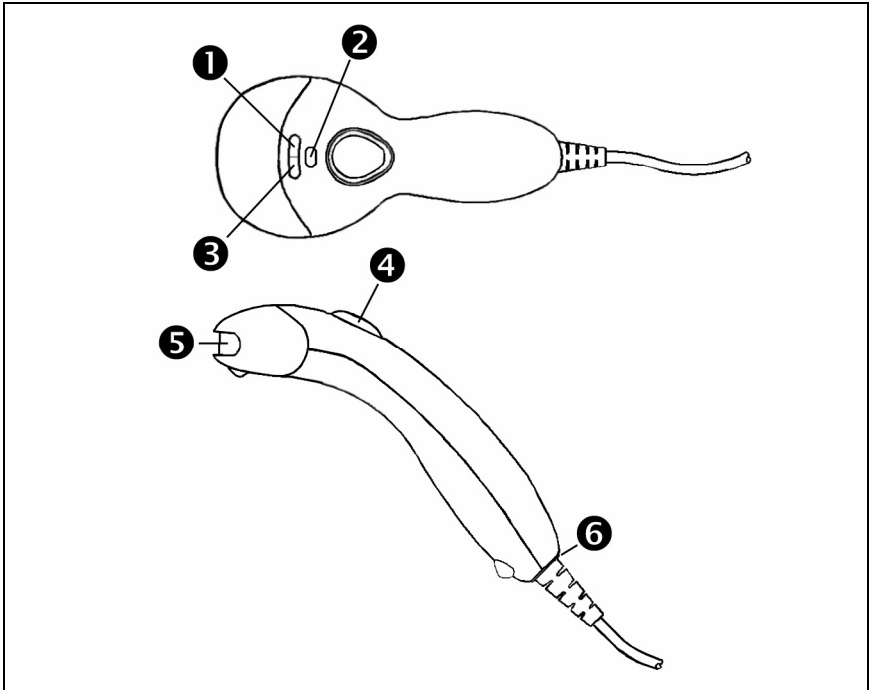

Figure 28.

SCANNER PARTS



Item No.	Description
1	White LED, <i>see page 18</i>
2	Yellow LED, available on the MS9544 only (<i>see page 18</i>).
3	CodeGate Button, available on the MS9544 only (<i>see page 10</i>).
4	Blue LED, <i>see page 18</i>
5	Output Window, Laser Aperture
6	Cable Connection, <i>see page 40 for connector pinouts</i>

Figure 29.

Audible

When the *VoyagerPDF* is in operation, it provides audible feedback. These sounds indicate the status of the scanner. Eight settings are available for the tone of the beep (normal, 6 alternate tones and no tone). To change the tone, refer to MetroSelect Single-Line Guide, MLPN 00-02544 or MetroSet2's help files.



One Beep

When the scanner *first* receives power, the blue LED will turn on, then the white LED will flash and the scanner will beep once. The white LED will remain on for the duration of the beep. The scanner is ready to scan.

When the scanner *successfully* reads a bar code, the white LED will flash and the scanner beeps once (if configured to do so). If the scanner does not beep once and the white light does not flash, then the bar code has *not* been successfully read.



Razzberry Tone

This tone is a failure indicator. Refer to Failure Modes on page 19.



Three Beeps - During Operation

When entering configuration mode, the white LED will flash while the scanner simultaneously beeps three times. The white and blue LEDs will continue to flash while in this mode. Upon exiting configuration mode, the scanner will beep three times, and the LEDs will stop flashing.

When configured, 3 beeps can also indicate a communications timeout during normal scanning mode.

When using one-code-configuration, the scanner will beep three times (the current selected tone), followed by a short pause then by a high tone and a low tone. This tells the user that the single configuration bar code has successfully configured the scanner.



Three Beeps - On Power Up

This is a failure indicator. Refer to Failure Modes on page 19.

Visual

The MS9544 has three LED indicators (blue, white and yellow) located on the head of the scanner. The MS9524 has two LED indicators (blue and white) located on the head of the scanner. When the scanner is on, the flashing or stationary activity of the LEDs indicates the status of the current scan and the scanner.



Blue, White & Yellow (MS9544's Only) LEDs are off

The LEDs will not be illuminated if the scanner is not receiving power from the host or transformer.

The scanner is stand-by mode, and CodeGate[®] is enabled. Present a bar code to the scanner and the blue LED will turn on when the laser turns on.



Steady Yellow (MS9544's Only)

The CodeGate button is not active. If a bar code is in the scan field, the laser will turn on. The bar code will be decoded and transmitted to the host automatically.

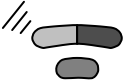

Steady Blue

When the laser is active, the blue LED is illuminated. The blue LED will remain illuminated until the laser is deactivated. (*Default Mode Only*)

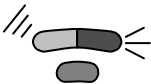

Steady Blue and Single White Flash

When the scanner successfully reads and transmits a bar code, the white LED will flash and the scanner will beep once. If the white LED does not flash or the scanner does not beep once, then the bar code has not been successfully read and/or transmitted. (*Default Mode Only*)

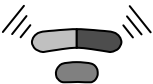

Steady Blue and Steady White

After a successful scan, the scanner transmits the data to the host device. Some communication modes require that the host inform the scanner when data is ready to be received. If the host is not ready to accept the information, the scanner's white LED will remain on until the data can be transmitted.

Visual



Alternating Flashing of Blue and White

This indicates the scanner is configuration mode. A razzberry tone indicates that an invalid bar code has been scanned while in this mode.

The scanner needs to have a Flash ROM upgrade if the alternating flashing of the white and blue LEDs occurs during startup and is accompanied by three beeps.

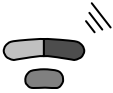

Steady White, Blue off

This indicates the scanner may be waiting for communication from the host.

Failure Modes



One Razzberry Tone – On Power Up or During Scanning

This indicates the scanner has experienced motor or laser failure

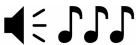

Three Beeps – On Power Up

If the scanner beeps 3 times on power up then the non-volatile memory (NovRAM) that holds the scanner configuration has failed. If the scanner does not respond after reconfiguring, return the scanner for repair to an authorized service center.

CONFIGURATION MODES

The MS9524/44 VoyagerPDF Series has 3 modes of configuration.

- **Bar Codes**

VoyagerPDF or VoyagerPDF with CodeGate can be configured by scanning the bar codes located in Metrologic's configuration guides, MLPN 00-02544 and MLPN 00-02990 or MetroSet2's help files. Please refer to these guides for instructions. These manuals can be downloaded for FREE from Metrologic's website (www.metrologic.com).

- **MetroSet2**

This user-friendly Windows-based configuration program allows you to simply 'point-and-click' at the desired scanner options. This program can be downloaded for FREE from Metrologic' website (www.metrologic.com), or set-up disks can be ordered by calling 1-800-ID-METRO.

- **Serial Configuration**

This mode of configuration is ideal for OEM applications. This mode gives the end-user the ability to send a series of commands using the serial port of the host system. The commands are equivalent to the numerical values of the bar codes located in the MetroSelect Single-Line Configuration Guide (MLPN 00-02544).

How does Serial Configuration work?

1. Each command sent to the scanner is the ASCII representation of each numeral in the configuration bar code. The entire numeric string is framed with an ASCII [stx] and an ASCII [etx].

EXAMPLE #1:

Command for Disabling Codabar

Command = [stx]100104[etx]

String Sent to Scanner = 02h 31h 30h 30h 31h 30h 34h 03h

(All values are hexadecimal).

2. If the command sent to the scanner is valid, the scanner will respond with an [ack].
3. If the command sent to the scanner is invalid, the scanner will respond with a [nak].

NOTE: If this occurs, the end-user must start over at the very beginning of the configuration sequence. Simply re-transmitting the invalid command will not work. You must start over.

CONFIGURATION MODES

4. During configuration, the motor and laser turn off. **YOU CANNOT SCAN A BAR CODE WHILE IN SERIAL CONFIGURATION MODE.**
5. There is a 20 second window between commands. If a 20-second timeout occurs, the scanner will send a [nak] and you must start over.
6. To enter serial configuration mode, send the following command [stx]999999[etx].
7. To exit serial configuration mode, send the following command [stx]999999[etx], the scanner will respond with an [ack] followed by 3 beeps.
8. This mode uses the current Baud Rate, Parity, Stop Bits and Data Bits settings that are configured in the scanner. The default settings of the scanner are 9600, Space, 2, 7 respectively. If a command is sent to the scanner to change any of these settings, the change will NOT take effect until after serial configuration mode is exited.

EXAMPLE #2:

The following example will set the scanner to the factory default settings, Disable Scanning of Code 128 bar codes, change the beeper tone, and add a "G" as a configurable prefix.

<u>FEATURE</u>	<u>HOST COMMAND</u>	<u>ASCII REPRESENTATION RESPONSE</u>	<u>SCANNER RESPONSE</u>
Enter Configuration Mode	[stx]999999[etx]	02h 39h 39h 39h 39h 39h 39h 03h	[ack] or 06h
Load Defaults	[stx]999998[etx]	02h 39h 39h 39h 39h 39h 38h 03h	[ack] or 06h
Disable Code 128	[stx]100113[etx]	02h 31h 30h 30h 31h 31h 33h 03h	[ack] or 06h
Alternate Tone 1	[stx]318565[etx]	02h 33h 31h 38h 35h 36h 35h 03h	[ack] or 06h
Prog. Prefix #1	[stx]903500[etx]	02h 39h 30h 33h 35h 30h 30h 03h	[ack] or 06h
Code Byte 0	[stx]0[etx]	02h 30h 03h	[ack] or 06h
Code Byte 7	[stx]7[etx]	02h 37h 03h	[ack] or 06h
Code Byte 1	[stx]1[etx]	02h 31h 03h	[ack] or 06h
Exit Configuration Mode	[stx]999999[etx]	02h 39h 39h 39h 39h 39h 39h 03h	[ack] or 06h

The scanner will beep three times!

The commands sent to the scanner do not include the small superscripted '3' that you see in front of each bar code string in the MetroSelect manual. **THE '3' SHOULD NOT BE SENT, IT IS A CODE TYPE DESIGNATION ONLY!**

As you will note for commands requiring additional bar codes to be scanned (such as prefixes, suffixes, timeouts, etc.), simply send the code bytes in the same order that you would normally scan the bar codes.

CONFIGURATION MODES

EXAMPLE #3:

The following example shows the events that occur when an invalid bar code is sent. This sample will load the factory default settings and then set the baud rate to 19200.

<u>FEATURE</u>	<u>HOST COMMAND</u>	<u>ASCII REPRESENTATION RESPONSE</u>	<u>SCANNER RESPONSE</u>
Enter Configuration Mode	[stx]999999[etx]	02h 39h 39h 39h 39h 39h 39h 03h	[ack] or 06h
Load Defaults	[stx]999999[etx]	02h 39h 39h 39h 39h 39h 3Ah 03h	[ack] or 06h
Invalid command was sent, you must start over!			
Enter Configuration Mode	[stx]999999[etx]	02h 39h 39h 39h 39h 39h 39h 03h	[ack] or 06h
Load Defaults	[stx]999998[etx]	02h 39h 39h 39h 39h 39h 39h 03h	[ack] or 06h
19200 Baud Rate	[stx]415870[etx]	02h 34h 31h 35h 38h 37h 30h 03h	[ack] or 06h
Exit Configuration Mode	[stx]999999[etx]	02h 39h 39h 39h 39h 39h 39h 03h	[ack] or 06h

The scanner will beep three times!

This example illustrates two important points.

First, if an invalid command is sent from the host, the scanner responds with a [nak] and the end-user must start over from the beginning.

Second, if a command is sent to change the Baud Rate, the new baud rate does not take effect until after the end-user exits configuration mode.

ABBREVIATED ASCII TABLE

Character	Hex Value	Decimal Value
[STX]	02h	2
[ETX]	03h	3
[ACK]	06h	6
[NAK]	15h	21
0	30h	48
1	31h	49
2	32h	50
3	33h	51
4	34h	52
5	35h	53
6	36h	54
7	37h	55
8	38h	56
9	39h	57

UPGRADING THE FLASH ROM FIRMWARE

The MetroSet2 program is a functional component of Metrologic's new line of Flash-based scanners. This program allows the user of a Metrologic scanner to quickly upgrade to a new or custom version of software. It requires the use of a personal computer running under Windows 95 or greater and the use of a communication port. The user merely connects the scanner to a communications port of the PC, launches the MetroSet2 program, and blasts off to new software upgrades.

Each MS9524/44, regardless of the version number or communication protocol, can be upgraded. In other words, all RS232 (-41), keyboard wedge (-47), light pen (-41), laser emulation (-00), OCIA (-9), IBM 468X/469X (-11), low speed USB (-38), and full speed USB (-40) units can be upgraded. To upgrade all units, a power supply and PowerLink cable (MLPN 54-54012) are required.

The upgrades and custom software versions will be supplied by Metrologic in files called Motorola S-record files. These files contain all the information needed to upgrade the scanner. Simply add this file to the working directory or retrieve from its current location.

The program guides the user with its simplistic one click approach. The user must first select the file; once selected and verified, the file is ready to be used in the upgrade. Press the button to upgrade the scanner, the unit will go into a "flash mode" – both the blue and white LEDs will be on. The user can follow the progress of the upgrade by watching the screen for details. When the upgrade is complete, the scanner will respond with its normal one beep on power up. If the single beep does not occur, the scanner did not upgrade properly. Contact Metrologic for additional details.

LABELS

Every scanner has labels and molded text located on the underside of the unit. The labels and text contain important information such as the unit's date of manufacture, serial number, CE and caution information. *Figure 30* provides examples of the labels and the molded text.

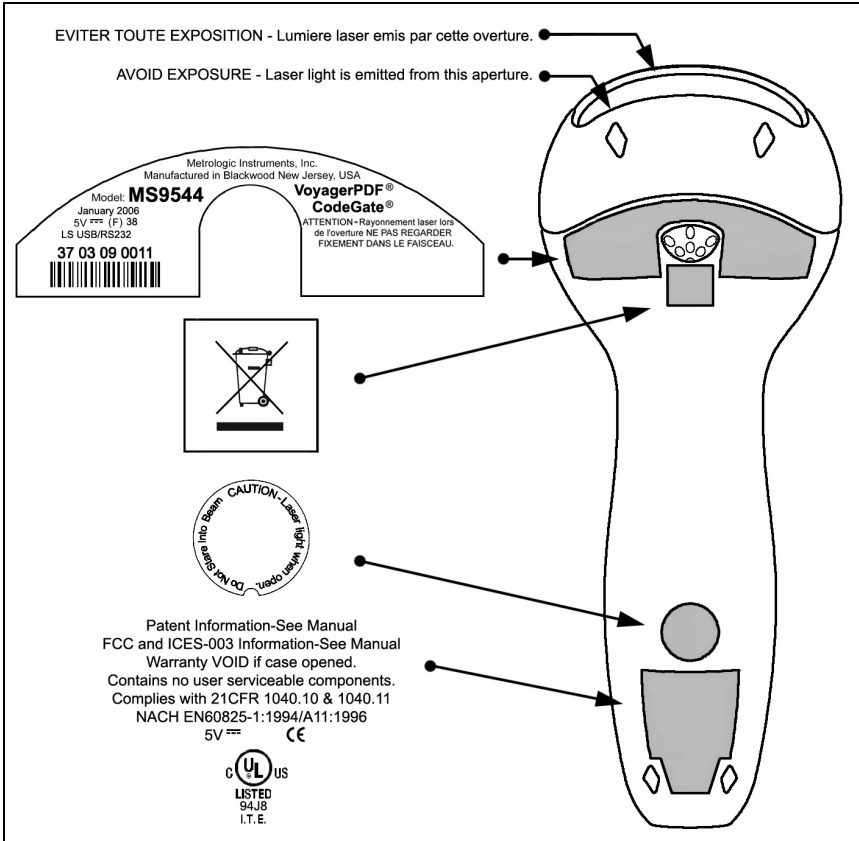

Figure 30

MAINTENANCE

The output window will need occasional cleaning to prevent smudges and dirt from interfering with scanning performance.

1. Spray glass cleaner onto lint free, non-abrasive cleaning cloth.
2. Gently wipe the scanner window.

DEPTH OF FIELD

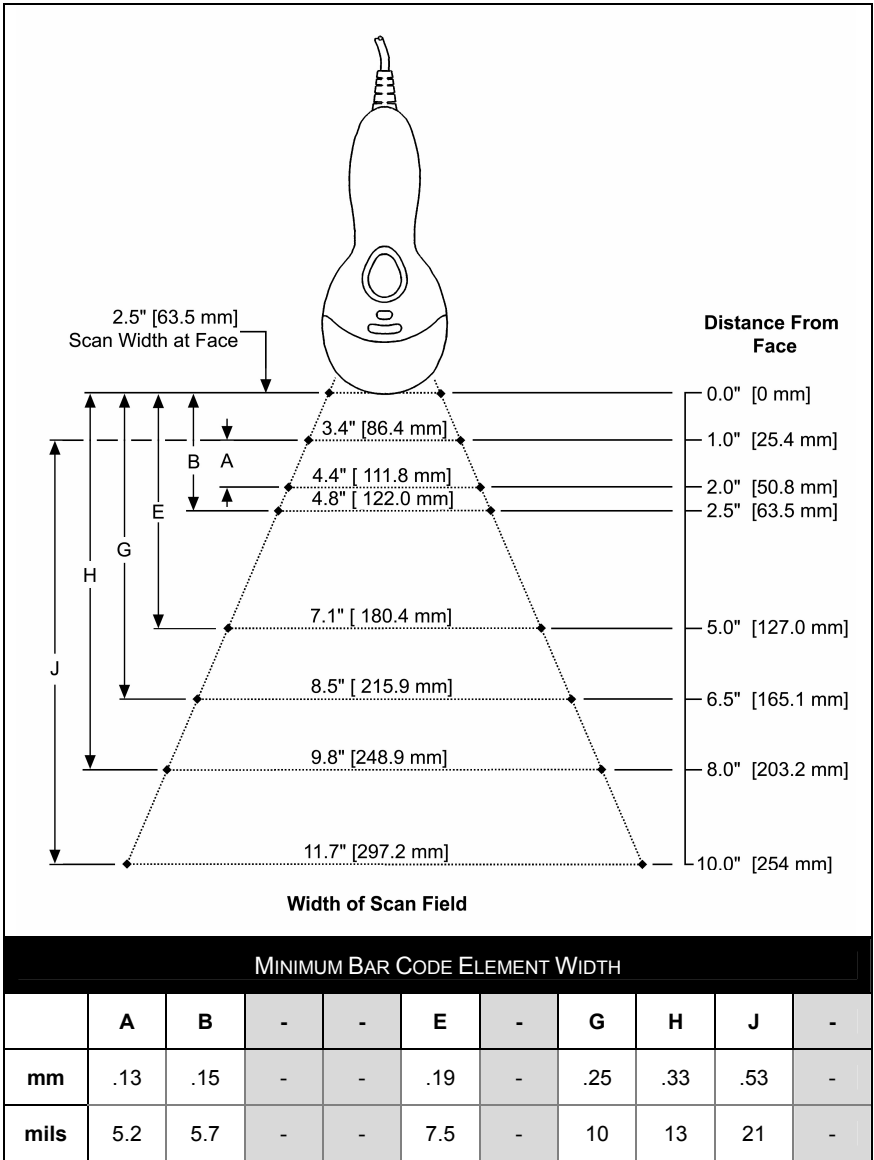

Figure 31.

Specifications subject to change without notice.

DEPTH OF FIELD

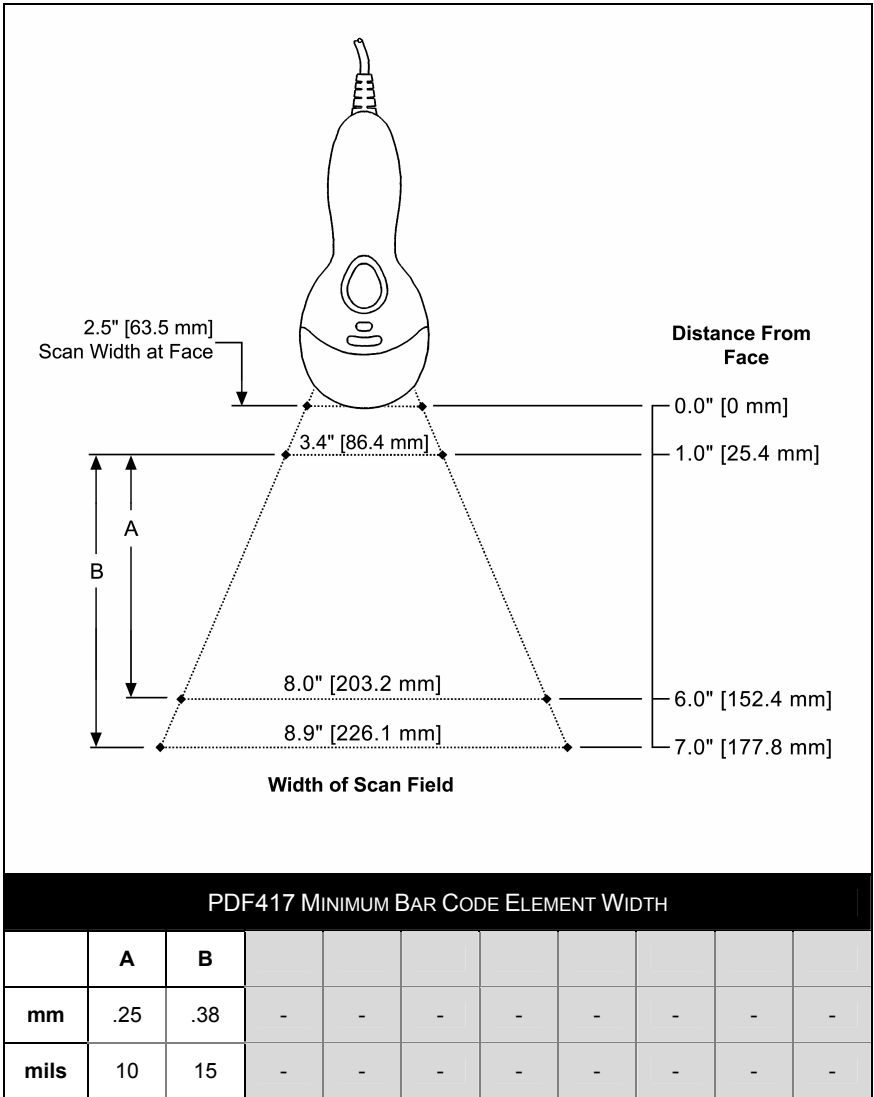

Figure 32.

Specifications subject to change without notice.

IR ACTIVATION

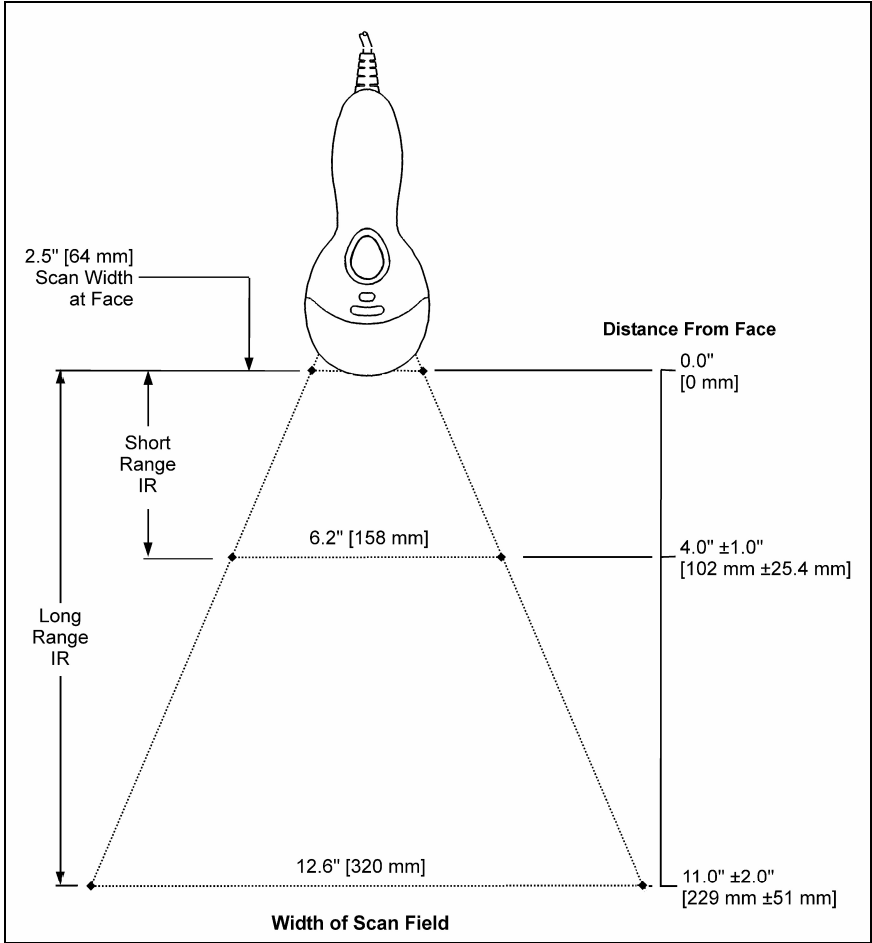

Figure 33.

Specifications subject to change without notice.

APPLICATIONS AND PROTOCOLS

The model number on each scanner includes the scanner number and factory default communications protocol.

Scanner	Version Identifier	Communication Protocol(s)
MS9524 and MS9544	-9	OCIA* and RS232 Transmit/Receive
	-00	Laser Emulation* and RS232 Transmit/Receive*
	-11	IBM 468X/469X, RS232-TXD, RXD, RTS, CTS
	-14	RS232-TXD, RXD, RTS, CTS, DTR, DSR
	-38	Low Speed, Serial Emulation or Keyboard Emulation Mode
	-40	Full Speed USB
	-41	RS232/Light Pen Emulation*
	-47	Keyboard Wedge, Stand-Alone Keyboard and RS232 Transmit/Receive

* PDF bar codes are transmitted as Code 39 for these interfaces. Acceptance on host side is dependent on the host's ability to handle large amounts of data.

The MS9524/44 Series Hand-Held Laser Scanner with built-in PC Keyboard Wedge Interface is designed for Keyboard emulation use only. Many RS232 configurable functions available in other Metrologic scanners are also available as keyboard wedge functions.

The following are the most important selectable options specific to the keyboard wedge:

Keyboard Type

- **AT (includes IBM® PS2 models 50, 55, 60, 80)
- IBM PS2 (includes models 30, 70, 8556)

Keyboard Country Type

- | | | |
|-----------|------------|------------------|
| • **USA | • German | • Spanish |
| • Belgium | • Italian | • Swiss |
| • French | • Japanese | • United Kingdom |

** Default setting. Refer the Default Settings chart on pages 35 - 39. For information on how to change the default settings, refer to help files in MetroSet2 or the MetroSelect Single-Line Configuration Guide.

TROUBLESHOOTING GUIDE

The following guide is for reference purposes only. Contact a Metrologic representative at 1-800-ID-Metro or 1-800-436-3876 to preserve the limited warranty terms.

All Interfaces

MS9524/44 Series Troubleshooting Guide		
Symptoms	Possible Causes	Solution
The unit has no LEDs, beep or laser.	No power is being supplied to the unit.	<p>Check the transformer, power outlet and power strip.</p> <p>Check to make sure the cable is plugged into the scanner.</p> <p>Check to make sure the power supply is plugged into the PowerLink cable.</p>
At power up the unit beeps 3 times.	There is a non-volatile RAM failure.	Contact a Metrologic service representative.
At power up there is a continuous razz tone.	There is a RAM or ROM failure.	
The unit emits a razz tone.	There is a VLD failure.	
	There is a scanning mechanism failure.	
The unit scans, communicates and beeps twice.	The same symbol timeout set too short.	Adjust same symbol timeout for a longer time.
The unit powers up but does not beep.	The beeper is disabled and no tone is selected.	Enable the beeper and select a tone.
The unit powers up, but does not scan and/or beep.	The bar code symbology being scanned has not been enabled.	<p>UPC/EAN, Code 39, interleaved 2 of 5, Code 93, Code 128, Codabar and PDF are enabled by default.</p> <p>Verify that the type of bar code being read has been selected.</p>
	The bar code being scanned does not satisfy the configured criteria for character length lock or minimum length.	<p>Verify that the bar code being scanned falls into the configured criteria.</p> <p><i>The scanner defaults to a minimum of 3 character bar code.</i></p>

TROUBLESHOOTING GUIDE

Symptoms	Possible Causes	Solution
The unit scans a bar code, but locks up after the first scan and the white LED stays on.	The unit is configured to support some form of host handshaking, but is not receiving the signal.	If the unit is setup to support ACK/NAK, RTS/CTS, XON/XOFF or D/E, verify that the host cable and host are supporting the handshaking properly.
The unit scans, but the data transmitted to the host is incorrect.	The unit's data format does not match the host system's requirements.	Verify that the unit's data format matches that required by the host. Make sure that the scanner is connected to the proper host port.
The unit beeps at some bar codes and NOT for others of the same bar code symbology.	The print quality of the bar code is suspect.	Check print mode. The type of printer could be the problem. Change print settings. i.e. change to econo mode or high speed.
	The aspect ratio of the bar code is out of tolerance.	
	The bar code may have been printed incorrectly.	Check if it is a check digit/character/or border problem.
	The unit is not configured correctly for this type of bar code.	
The minimum symbol length setting does not work with the bar code.	Check if the correct minimum symbol length is set.	
The unit scans the bar code but there is no data.	The configuration is not set correctly.	Make sure the scanner is configured for the appropriate mode.
The unit scans but the data is not correct.		Make sure that the proper PC type, AT or PS2, is selected. Verify correct country code and data formatting are selected. Adjust inter-character delay symptom.
The unit is transmitting each character twice.		Increase interscan code delay setting. Adjust whether the F0 break is transmitted. It may be necessary to try this in both settings.

TROUBLESHOOTING GUIDE

Symptoms	Possible Causes	Solution
Alpha characters show as lower case.	The computer is in Caps Lock mode.	Enable Caps Lock detect setting of the scanner to detect if the PC is operating in Caps Lock.
Everything works except for a couple of characters.	These characters may not be supported by that country's key look up table.	Try operating the scanner in Alt mode.
The unit powers up OK and scans OK but does not communicate properly to the host.	The com port at the host is not working or not configured properly.	Check to make sure that the baud rate and parity of the scanner and the communication port match and the configuration is looking for RS232 data.
	The cable is not connected to the correct com port.	Check to make sure that the cable is connected to the correct com port.
Characters are being dropped.	Inter-character delay needs to be added to the transmitted output.	Add some inter-character delay to the transmitted output by using the MetroSelect Single-Line Configuration Guide MLPN 00-02544.

RS232 Demonstration Program

If an RS232 scanner is not communicating with your IBM compatible PC, key in the following BASIC program to test that the communication port and scanner are working.

This program is for demonstration purposes only. It is only intended to prove that cabling is correct, the com port is working, and the scanner is working. If the bar code data displays on the screen while using this program, it only demonstrates that the hardware interface and scanner are working. At this point, investigate whether the application software and the scanner configuration match.

If the application does not support RS232 scanners, a software wedge program that will take RS232 data and place it into a keyboard buffer may be needed. This program tells the PC to ignore RTS-CTS, Data Set Ready (DSR) and Data Carrier Detect (DCD) signals. If the demonstration program works and yours still does not, jumper RTS to CTS and Data Terminal Reading (DTR) to DCD and DSR on the back of your PC.

```
10     CLS
20     ON ERROR GOTO 100
30     OPEN "COM1:9600,S,7,1,CSO,DSO,CD0,LF" AS#1
35     PRINT "SCAN A FEW BAR CODES"
40     LINE INPUT #1, BARCODE$
50     PRINT BARCODE$
60     K$ = INKEY$: IF K$ = CHR$(27) THEN GOTO 32766
70     GOTO 40
100    PRINT "ERROR NO.:", ERR ; "PRESS ANY KEY TO TERMINATE."
110    KK$ = INKEY$: IF K$ = "" THEN GOTO 110
32766  CLOSE: SYSTEM
32767  END
```

DESIGN SPECIFICATIONS

DESIGN SPECIFICATIONS	
OPERATIONAL	
Light Source:	Visible Laser Diode 650 nm
Laser Power:	Less than 1 mW (peak)
Depth of Scan Field:	0 mm – 200 mm (0" – 8") for 0.330 mm (13 mil) bar code at default setting
Scan Speed:	180 ±10 scan lines per second
Scan Pattern:	Single scan line
Minimum Bar Width:	0.127 mm (5.0 mil)
Infrared Activation:	Long Range: 0 mm – 280 mm ± 50 mm (0" – 11" ± 2") Short Range: 0 mm – 100 mm ± 25 mm (0" – 4" ± 1")
Decode Capability:	Autodiscriminates all standard 1-D bar codes, RSS-14, PDF417 and truncated PDF417; for others symbologies call a Metrologic service representative
System Interfaces:	PC Keyboard Wedge, RS232, OCIA, Light Pen Emulation, Laser Emulation, IBM 468X/469X, Stand-Alone Keyboard, USB (low speed and full speed)
Print Contrast:	30% minimum reflectance difference
Number Characters Read:	Up to 80 data characters on 1D; 1850 text characters for PDF417
Roll, Pitch, Yaw:	42°, 68°, 52°
Beeper Operation:	7 tones or no beep
Indicators (LED) <i>Default Settings</i>	Blue = laser on, ready to scan; White = good read; Yellow (MS9544 Only) = auto trigger mode active
MECHANICAL	
Length:	198 mm (7.8")
Width:	Handle - 45 mm (1.8"), Head - 78 mm (3.1")
Depth:	40 mm (1.6")
Weight:	149 g (5.25 oz)
Termination:	10 pin modular RJ45

Specifications subject to change without notice.

DESIGN SPECIFICATIONS

DESIGN SPECIFICATIONS	
ELECTRICAL	
Input Voltage:	5.0VDC \pm 0.25V
Power:	Operating = 900 mW (typical) Standby = 325 mW (typical)
Current:	Operating = 250 mA @ 5VDC (typical) Standby = 100 mA @ 5VDC (typical)
DC Transformers:	Class 2; 5.2VDC @ 650 mA
Laser Class 1:	IEC 60825-1:1993+A1:1997+A2:2001 EN 60825-1:1994+A11:1996+A2:2001
EMC:	FCC, ICES-003 & EN55022 Class B Refer to page 45 for Class B cable restrictions.
ENVIRONMENTAL	
Temperature:	Operating = 0°C to 40° (32° to 104°F) Storage = -40°C to 60°C (-40°F to 140°F)
Humidity:	5% to 95% relative humidity, non-condensing
Light Levels:	Immune to direct exposure of normal office and factory lighting conditions, as well as direct exposure to sunlight.
Shock:	Designed to withstand 1.5 m (5') drops
Contaminants:	Sealed to resist airborne particulate contaminants
Ventilation:	None required

Specifications subject to change without notice.

DEFAULT SETTINGS

Many functions of the scanner can be *configured* or enabled/disabled. The scanner is shipped from the factory configured to a set of default conditions. All default parameters of the scanner have an asterisk (*) marked in the default column. If an asterisk is not in the default column then the default setting is *off* or *disabled*. Every interface does not support every parameter. A check mark (✓) will appear in the interface column if it supports the parameter listed.

PARAMETER	DEFAULT	OCIA	RS232	LIGHT PEN	IBM 46XX	KBW	USB	LASER EMULATION
Normal Scan Mode	*	✓	✓	✓	✓	✓	✓	✓
Continuous Scan Mode		✓	✓	✓	✓	✓	✓	✓
Blinky Scan		✓	✓	✓	✓	✓	✓	✓
Continuous Blinky Scan		✓	✓	✓	✓	✓	✓	✓
Custom (one shot) Scan		✓	✓	✓	✓	✓	✓	✓
Long-Range In-Stand	*	✓	✓	✓	✓	✓	✓	✓
Short-Range In-Stand		✓	✓	✓	✓	✓	✓	✓
Long-Range Out-of-Stand	*	✓	✓	✓	✓	✓	✓	✓
Short-Range Out-of-Stand		✓	✓	✓	✓	✓	✓	✓
CodeGate Active In-Stand		✓	✓	✓	✓	✓	✓	✓
CodeGate Inactive In-Stand	*	✓	✓	✓	✓	✓	✓	✓
CodeGate Active Out-of-Stand	*	✓	✓	✓	✓	✓	✓	✓
CodeGate Inactive Out-of-Stand		✓	✓	✓	✓	✓	✓	✓
UPC/EAN	*	✓	✓	✓	✓	✓	✓	✓
Code 128	*	✓	✓	✓	✓	✓	✓	✓
Code 93	*	✓	✓	✓	✓	✓	✓	✓
Codabar	*	✓	✓	✓	✓	✓	✓	✓
Interleaved 2 of 5 (ITF)	*	✓	✓	✓	✓	✓	✓	✓
MOD 10 check on ITF		✓	✓	✓	✓	✓	✓	✓
Code 11		✓	✓	✓	✓	✓	✓	✓
Code 39	*	✓	✓	✓	✓	✓	✓	✓
Full ASCII Code 39		✓	✓	✓	✓	✓	✓	✓
PDF	*	✓	✓	✓	✓	✓	✓	✓
PDF CodeGate Active Out-of-Stand		✓	✓	✓	✓	✓	✓	✓

DEFAULT SETTINGS

PARAMETER	DEFAULT	OCIA	RS232	LIGHT PEN	IBM 46XX	KBW	USB	LASER EMULATION
PDF CodeGate Inactive Out-of-Stand	*	✓	✓	✓	✓	✓	✓	✓
PDF CodeGate Active In-Stand		✓	✓	✓	✓	✓	✓	✓
PDF CodeGate Inactive In-Stand	*	✓	✓	✓	✓	✓	✓	✓
Mod 43 Check on Code 39		✓	✓	✓	✓	✓	✓	✓
MSI-Plessey 10/10 Check Digit		✓	✓	✓	✓	✓	✓	✓
MSI-Plessey Mod 10 Check Digit	*	✓	✓	✓	✓	✓	✓	✓
Paraf Support ITF		✓	✓	✓	✓	✓	✓	✓
ITF Symbol Lengths	Variable	✓	✓	✓	✓	✓	✓	✓
Minimum Symbol Length	3	✓	✓	✓	✓	✓	✓	✓
Symbol Length Lock	None	✓	✓	✓	✓	✓	✓	✓
Bars High as Code 39	*			✓				✓
Spaces High as Code 39				✓				✓
Bars High as Scanned				✓				✓
Spaces High as Scanned				✓				✓
DTS/SIEMENS		✓						
DTS/NIXDORF	*	✓						
NCR F		✓						
NCR S		✓						
Poll light pen source				✓				✓
Beeper tone	Normal	✓	✓	✓	✓	✓	✓	✓
Beep/transmit sequence	Before transmit	✓	✓	✓	✓	✓	✓	✓
PDF Audible Processing Indicator - Enabled	*	✓	✓	✓	✓	✓	✓	✓
PDF Audible Processing Indicator - Disabled		✓	✓	✓	✓	✓	✓	✓
Communication timeout	None	✓	✓	✓	✓	✓	✓	✓
Razzberry tone on timeout		✓	✓	✓	✓	✓	✓	✓
Three beeps on timeout		✓	✓	✓	✓	✓	✓	✓

DEFAULT SETTINGS

PARAMETER	DEFAULT	OCIA	RS232	LIGHT PEN	IBM 46XX	KBW	USB	LASER EMULATION
Same symbol rescan timeout 250 msec		✓	✓	✓	✓	✓	✓	✓
Same symbol rescan timeout 375 msec		✓	✓	✓	✓	✓	✓	✓
Same symbol rescan timeout: 500 msec)		✓	✓	✓	✓	✓	✓	✓
Same symbol rescan timeout 625 msec		✓	✓	✓	✓	✓	✓	✓
Same symbol rescan timeout 750 msec		✓	✓	✓	✓	✓	✓	✓
Same symbol rescan timeout 875 msec	*	✓	✓	✓	✓	✓	✓	✓
Same symbol rescan timeout: 1000 msec		✓	✓	✓	✓	✓	✓	✓
No Same symbol timeout		✓	✓	✓	✓	✓	✓	✓
Infinite Same symbol timeout		✓	✓	✓	✓	✓	✓	✓
Inter-character delay configurable in 1 msec steps (max 255 msec)	1 msec 10 msec in KBW	✓	✓	✓	✓	✓	✓	✓
Number of scan buffers (<i>maximum</i>)	4	✓	✓	✓	✓	✓	✓	✓
Transmit UPC-A check digit	*	✓	✓	✓	✓	✓	✓	✓
Transmit UPC-E check digit		✓	✓	✓	✓	✓	✓	✓
Expand UPC-E		✓	✓	✓	✓	✓	✓	✓
Convert UPC-A to EAN-13		✓	✓	✓	✓	✓	✓	✓
Transmit lead zero on UPC-E		✓	✓	✓	✓	✓	✓	✓
Transmit UPC-A number system	*	✓	✓	✓	✓	✓	✓	✓
Transmit UPC-A Manufacturer ID#	*	✓	✓	✓	✓	✓	✓	✓
Transmit UPC –A Item ID#	*	✓	✓	✓	✓	✓	✓	✓
Transmit Codabar Start/Stop Characters		✓	✓		✓	✓	✓	
CLSI Editing (Enable)		✓	✓		✓	✓	✓	
Transmit Mod 43 Check digit on Code 39		✓	✓		✓	✓	✓	
Transit Mod 10/ITF		✓	✓		✓	✓	✓	
Transmit MSI-Plessey		✓	✓		✓	✓	✓	

DEFAULT SETTINGS

PARAMETER	DEFAULT	OCIA	RS232	LIGHT PEN	IBM 46XX	KBW	USB	LASER EMULATION
Parity	Space		✓		✓		✓	
Baud Rate	9600		✓					
8 Data Bits			✓					
7 Data Bits	*		✓					
Stop Bits	2		✓					
Transmit Sanyo ID Characters			✓			✓		
Nixdorf ID			✓			✓		
LRC Enabled			✓			✓		
UPC Prefix			✓			✓		
UPC Suffix			✓			✓		
Carriage Return	*		✓			✓		
Line Feed-Disabled by default in KBW	*		✓			✓		
Tab Prefix			✓			✓		
Tab Suffix			✓			✓		
"DE" Disable Command			✓					
"FL" Laser			✓					
Enable Command			✓					
DTR Handshaking support			✓					
RTS/CTS Handshaking			✓					
Character	*		✓					
Message RTS/CTS			✓					
XON/XOFF Handshaking			✓					
ACK/NAK			✓					
Two Digit Supplements		✓	✓	as code 39	✓	✓	✓	as code 39
Five Digit Supplements		✓	✓	as code 39	✓	✓	✓	as code 39

DEFAULT SETTINGS

PARAMETER	DEFAULT	OCIA	RS232	LIGHT PEN	IBM 46XX	KBW	USB	LASER EMULATION
Bookland		✓	✓	as code 39	✓	✓	✓	as code 39
977 (2 digit) Supplemental Requirement		✓	✓	✓	✓	✓	✓	✓
Supplements are not Required	*	✓	✓	✓	✓	✓	✓	✓
Two Digit Redundancy	*	✓	✓	✓	✓	✓	✓	✓
Five digit Redundancy		✓	✓	✓	✓	✓	✓	✓
100 msec to Find Supplement Configurable in 100 msec steps (max 800 msec)	*	✓	✓	✓	✓	✓	✓	✓
Coupon Code 128		✓	✓	as code 39	✓	✓	✓	as code 39
† Configurable Code Lengths	7 avail	✓	✓	✓	✓	✓	✓	✓
† Code Selects with Configurable Code Length Locks	3 avail	✓	✓	✓	✓	✓	✓	✓
Configurable Prefix Characters	10 avail		✓			✓		
Suffix Characters	10 avail		✓			✓		
Prefixes for Individual Code Types			✓			✓		
Editing		✓	✓	✓	✓	✓	✓	✓
Inter Scan-Code Delay Configurable (100 µsec steps)	800 µsec					✓		
Function/Control Key Support								
Minimum Element Width Configurable in 5.6 µsec Steps	1 msec			✓				✓

† These options are mutually exclusive. One can not be used in conjunction with the other.

SCANNER AND CABLE TERMINATIONS

Scanner Pinout Connections

The MS9524 and MS9544 scanner interfaces terminate to a 10-pin modular jack. The serial # label indicates the interface enabled when the scanner is shipped from the factory.

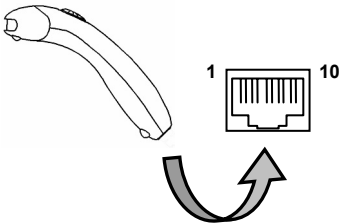

MS9524/44-41 RS232C and Light Pen Emulation	
Pin	Function
1	Ground
2	RS232 Transmit Output
3	RS232 Receive Input
4	RTS Output
5	CTS Input
6	DTR Input/LTPN Source
7	Reserved
8	LTPN Data
9	+5VDC
10	Shield Ground

MS9524/44-47 Keyboard Wedge & Stand-Alone Keyboard	
Pin	Function
1	Ground
2	RS232 Transmit Output
3	RS232 Receive Input
4	PC Data
5	PC Clock
6	KB Clock
7	PC +5V
8	KB Data
9	+5VDC
10	Shield Ground

MS9524/44-11 IBM 468X/469X	
Pin	Function
1	Ground
2	RS232 Transmit Output
3	RS232 Receive Input
4	RTS Output
5	CTS Input
6	DTR Input
7	IBM B-Transmit
8	IBM A+ Receive
9	+5VDC
10	Shield Ground

SCANNER AND CABLE TERMINATIONS

MS9524/44-9 OCIA	
Pin	Function
1	Ground
2	RS232 Transmit Output
3	RS232 Receive Input
4	RDATA
5	RDATA Return
6	Clock In
7	Clock Out
8	Clock in Return/Clock out Rtrn
9	+5VDC
10	Shield Ground

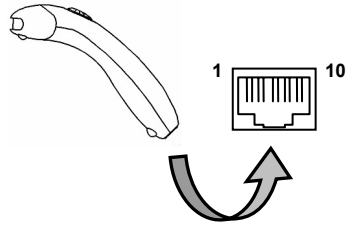

MS9524/44-00 Laser Emulation	
Pin	Function
1	Ground
2	RS232 Transmit Output
3	RS232 Receive Input
4	Flip Sense/Start of Scan Output
5	Proximity Detect/Trigger Emulation Output
6	Scan/Laser Enable Input
7	Reserved
8	Data Out
9	+5VDC
10	Shield Ground

MS9524/44-14 RS232	
Pin	Function
1	Ground
2	RS232 Transmit Output
3	RS232 Receive Input
4	RTS Output
5	CTS Input
6	DTR Input
7	Reserved
8	DSR Out
9	+5VDC
10	Shield Ground



MS9524/44-40 Full Speed USB MS9524/44-38 Low Speed USB	
Pin	Function
1	Ground
2	RS232 Transmit Output
3	RS232 Receive Input
4	RTS Output
5	CTS Input
6	D+
7	PC +5V/V_USB
8	D-
9	N/C
10	Drain Wire

SCANNER AND CABLE TERMINATIONS

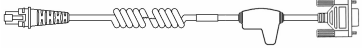
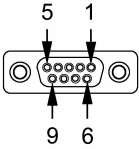
Cable Connector Configurations (Host End)

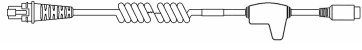
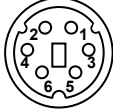

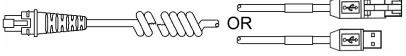
RS232 PowerLink Cable MLPN 53-53000x-3		
Pin	Function	 <p>9-Pin D-Type Connector</p>
1	Shield Ground	
2	RS232 Transmit Output	
3	RS232 Receive Input	
4	DTR Input/Light Pen Source	
5	Power/Signal Ground	
6	Light Pen Data <i>(DSR Out for -14 interfaces)</i>	
7	CTS Input	
8	RTS Output	
9	+5VDC	

Stand-Alone Keyboard PowerLink Cable MLPN 53-53020x-3		
Pin	Function	 <p>6-Pin Male Mini-DIN Connector</p>
1	PC Data	
2	NC	
3	Power Ground	
4	+5VDC PC Power to KB	
6	NC	

USB Cables MLPN 53-53213x-N-3, 53-53214x-N-3 or 53-53235x-N-3			
Pin	Function	 <p>Locking Type A</p>	 <p>Non-Locking Type A</p>
1	PC +5V/V_USB		
2	D-		
3	D+		
4	Ground		
Shield	Shield		

SCANNER AND CABLE TERMINATIONS

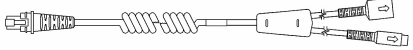
Cable Connector Configuration (Host End)

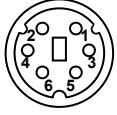
Keyboard Wedge PowerLink Cable 53-53002x-3		
Pin	Function	 5-Pin DIN, Female
1	Keyboard Clock	
2	Keyboard Data	
3	No Connect	
4	Power Ground	
5	+5 Volts DC	 6-Pin DIN, Male
Pin	Function	
1	PC Data	
2	No Connect	
3	Power Ground	
4	+5 Volts DC	
5	PC Clock	
6	No Connect	

Metrologic will supply an adapter cable with a 5-pin DIN male connector on one end and a 6-pin mini DIN female connector on the other. According to the termination required, connect the appropriate end of the adapter cable to the PowerLink cable, leaving the necessary termination exposed for connecting to the keyboard and the keyboard port on the PC.

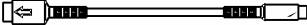
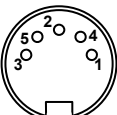
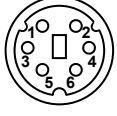
Keyboard Wedge Adapter Cable		
Pin	Function	 5-Pin DIN, Male
1	PC Clock	
2	PC Data	
3	No Connect	
4	Power Ground	
5	+5 Volts DC	 6-pin Mini DIN, Female
Pin	Function	
1	Keyboard Data	
2	No Connect	
3	Power Ground	
4	+5 Volts DC	
5	Keyboard Clock	
6	No Connect	

LIMITED WARRANTY

The MS9524/44 series scanners are manufactured by Metrologic at its Blackwood, New Jersey, USA facility and at its Suzhou, China facility. The MS9524/44 series scanners have a five (5) year limited warranty from the date of manufacture. Metrologic warrants and represents that all MS9524/44 series scanners are free of all defects in material, workmanship and design, and have been produced and labeled in compliance with all applicable US Federal, state and local laws, regulations and ordinances pertaining to their production and labeling.

This warranty is limited to repair, replacement of Product or refund of Product price at the sole discretion of Metrologic. Faulty equipment must be returned to the Metrologic facility in Blackwood, New Jersey, USA or Puchheim, Germany. To do this, contact Metrologic's Customer Service/Repair Department to obtain a Returned Material Authorization (RMA) number.

In the event that it is determined that the equipment failure is covered under the warranty, Metrologic shall, as its sole option, repair the Product or replace the Product with a functionally equivalent unit and return such repaired or replaced Product without charge for service or return freight, whether distributor, dealer/reseller, or retail consumer, or refund an amount equal to the original purchase price.

This limited warranty does not extend to any Product which, in the sole judgment of Metrologic, has been subjected to abuse, misuse, neglect improper installation, or accident, nor any damage due to use or misuse produced from integration of the Product into any mechanical, electrical or computer system. The warranty is void if the case of Product is opened by anyone other than Metrologic's repair department or authorized repair centers.

THIS LIMITED WARRANTY, EXCEPT AS TO TITLE, IS IN LIEU OF ALL OTHER WARRANTIES OR GUARANTEES, EITHER EXPRESS OR IMPLIED, AND SPECIFICALLY EXCLUDES, WITHOUT LIMITATION, WARRANTIES OF MERCHANTABILITY AND FITNESS FOR A PARTICULAR PURPOSE UNDER THE UNIFORM COMMERCIAL CODE, OR ARISING OUT OF CUSTOM OR CONDUCT. THE RIGHTS AND REMEDIES PROVIDED HEREIN ARE EXCLUSIVE AND IN LIEU OF ANY OTHER RIGHTS OR REMEDIES. IN NO EVENT SHALL METROLOGIC BE LIABLE FOR ANY INDIRECT OR CONSEQUENTIAL DAMAGES, INCIDENTAL DAMAGE, DAMAGES TO PERSON OR PROPERTY, OR EFFECT ON BUSINESS OR PROPERTY, OR OTHER DAMAGES OR EXPENSES DUE DIRECTLY OR INDIRECTLY TO THE PRODUCT, EXCEPT AS STATED IN THIS WARRANTY. IN NO EVENT SHALL ANY LIABILITY OF METROLOGIC EXCEED THE ACTUAL AMOUNT PAID TO METROLOGIC FOR THE PRODUCT. METROLOGIC RESERVES THE RIGHT TO MAKE ANY CHANGES TO THE PRODUCT DESCRIBED HEREIN.

North America Headquarters

Metrologic Instruments, Inc.
90 Coles Road
Blackwood, NJ 08012-4683

Customer Service: 1-800-ID-METRO
Tel: 856-228-8100
Fax: 856-228-6673
Email: info@metrologic.com
Website: www.metrologic.com

Germany

Metrologic Instruments GmbH
Dornierstrasse 2
82178 Puchheim b.
Munich, Germany

Tel: 49-89-89019-0
Fax: 49-89-89019-200
Email: info@europe.metrologic.com

EMC/EMI Notices

The following is applicable when the scanner cable is not greater in length than 3 meters (9.8 feet) when fully extended.

Les instructions ci-dessous s'appliquent aux câbles de scanner ne dépassant pas 3 mètres (9.8 pieds) de long en extension maximale.

Warnung! Mit der streifenkodeabtaster kabel >3 meters voll ausgelastet sein.

Notice

This equipment has been tested and found to comply with the limits for a Class B digital device, pursuant to Part 15 of the FCC rules. These limits are designed to provide reasonable protection against harmful interference in a residential installation. This equipment generates, uses and can radiate radio frequency and, if not installed and used in accordance with the instruction, may cause harmful interference to radio communications. However, there is no guarantee that interference will not occur in a particular installation. If this equipment does cause harmful interference to radio or television reception, which can be determined by turning the equipment off and on, the user is encouraged to try to correct the interference by one or more of the following measures:

- Reorient or relocate the receiving antenna
- Increase the separation between the equipment and receiver
- Connect the equipment into an outlet on a circuit different from that to which the receiver is connected
- Consult the dealer or an experienced radio TV technician for help

Changes or modifications not expressly approved by the party responsible for compliance could void the user's authority to operate the equipment.

Notice

This Class B digital apparatus complies with Canadian ICES-003.

Remarque

Cet appareil numérique de la class B est conforme à la norme NMB-003 du Canada.

EMC/EMI Notices

The following is applicable when the scanner cable is greater in length than 3 meters (9.8 feet) when fully extended.

Les instructions ci-dessous s'appliquent aux câbles de scanner dépassant 3 mètres (9.8 pieds) de long en extension maximale.

Warnung! Mit der streifenkodeabtaster kabel <3 meters voll ausgelastet sein.

Notice

This equipment has been tested and found to comply with limits for a Class A digital device, pursuant to part 15 of the FCC Rules. These limits are designed to provide reasonable protection against harmful interference when the equipment is operated in a commercial environment. This equipment generates, uses and can radiate radio frequency energy and, if not installed and used in accordance with the instruction manual, may cause harmful interference to radio communications. Operation of this equipment in a residential area is likely to cause harmful interference, in which case the user will be required to correct the interference at his own expense. Any unauthorized changes or modifications to this equipment could void the users authority to operate this device.

This device complies with part 15 of the FCC Rules. Operation is subject to the following two conditions: (1) This device may not cause harmful interference, and (2) this device must accept any interference received, including interference that may cause undesired operation.

Notice

This Class A digital apparatus complies with Canadian ICES-003.

Remarque

Cet appareil numérique de la classe A, conformément a la norme NMB-003 du Canada.

European Standard

Warning

This is a class A product. In a domestic environment this product may cause radio interference in which case the user may be required to take adequate measures.

Funkstöreigenschaften nach EN 55022:1998

Warnung!

Dies ist eine Einrichtung der Klasse A. Diese Einrichtung kann im Wohnbereich Funkstörungen verursachen; in diesem fall kann vom Betreiber verlangt werden, angemessene Maßnahmen durchführen.

Standard Europeo

Attenzione

Questo e' un prodotto di classe A. Se usato in vicinanza di residenze private potrebbe causare interferenze radio che potrebbero richiedere all'utilizzatore opportune misure.

Attention

Ce produit est de classe "A". Dans un environnement domestique, ce produit peut être la cause d'interférences radio. Dans ce cas l'utilisateur peut être amené à prendre les mesures adéquates.

Caution

Caution

Use of controls or adjustments or performance of procedures other than those specified herein may result in hazardous laser light exposure. Under no circumstances should the customer attempt to service the laser scanner. Never attempt to look at the laser beam, even if the scanner appears to be nonfunctional. Never open the scanner in an attempt to look into the device. Doing so could result in hazardous laser light exposure. The use of optical instruments with the laser equipment will increase eye hazard.

Atención

La modificación de los procedimientos, o la utilización de controles o ajustes distintos de los especificados aquí, pueden provocar una luz de láser peligrosa. Bajo ninguna circunstancia el usuario deberá realizar el mantenimiento del láser del escáner. Ni intentar mirar al haz del láser incluso cuando este no esté operativo. Tampoco deberá abrir el escáner para examinar el aparato. El hacerlo puede conllevar una exposición peligrosa a la luz de láser. El uso de instrumentos ópticos con el equipo láser puede incrementar el riesgo para la vista.

Attention

L'emploi de commandes, réglages ou procédés autres que ceux décrits ici peut entraîner de graves irradiations. Le client ne doit en aucun cas essayer d'entretenir lui-même le scanner ou le laser. Ne regardez jamais directement le rayon laser, même si vous croyez que le scanner est inactif. N'ouvrez jamais le scanner pour regarder dans l'appareil. Ce faisant, vous vous exposez à une rayonnement laser qui est dangereux. L'emploi d'appareils optiques avec cet équipement laser augmente le risque d'endommagement de la vision.

Achtung

Die Verwendung anderer als der hier beschriebenen Steuerungen, Einstellungen oder Verfahren kann eine gefährliche Laserstrahlung hervorrufen. Der Kunde sollte unter keinen Umständen versuchen, den Laser-Scanner selbst zu warten. Sehen Sie niemals in den Laserstrahl, selbst wenn Sie glauben, daß der Scanner nicht aktiv ist. Öffnen Sie niemals den Scanner, um in das Gerät hineinzusehen. Wenn Sie dies tun, können Sie sich einer gefährlichen Laserstrahlung aussetzen. Der Einsatz optischer Geräte mit dieser Laserausrüstung erhöht das Risiko einer Sehschädigung.

Attenzione

L'utilizzo di sistemi di controllo, di regolazioni o di procedimenti diversi da quelli descritti nel presente Manuale può provocare delle esposizioni a raggi laser rischiose. Il cliente non deve assolutamente tentare di riparare egli stesso lo scanner laser. Non guardate mai il raggio laser, anche se credete che lo scanner non sia attivo. Non aprite mai lo scanner per guardare dentro l'apparecchio. Facendolo potete esporVi ad una esposizione laser rischiosa. L'uso di apparecchi ottici, equipaggiati con raggi laser, aumenta il rischio di danni alla vista.



PATENTS

Patent Information

This METROLOGIC product may be covered by one or more of the following US Patents:

US Patent No. 5,260,553; 5,340,971; 5,340,973; 5,424,525; 5,468,951; 5,484,992; 5,525,789; 5,528,024; 5,591,953; 5,616,908; 5,627,359; 5,661,292; 5,777,315; 5,789,730; 5,789,731; 5,811,780; 5,825,012; 5,828,048; 5,883,375; 5,886,337; 5,895,907; 5,925,870; 5,925,871; 5,939,698; 6,029,894; 6,189,793; 6,209,789; 6,227,450; 6,283,375; 6,347,743; 6,412,700; 6,347,743; 6,412,700; 6,499,664; 6,575,369; 6,607,133; 6,637,655; 6,637,659; 6,863,217; 6,874,689; 6,905,071; D408,532;

No license right or sublicense is granted, either expressly or by implication, estoppel, or otherwise, under any METROLOGIC or third party intellectual property rights (whether or not such third party rights are licensed to METROLOGIC), including any third party patent listed above, except for an implied license only for the normal intended use of the specific equipment, circuits, and devices represented by or contained in the METROLOGIC products that are physically transferred to the user, and only to the extent of METROLOGIC's license rights and subject to any conditions, covenants and restrictions therein.

Other worldwide patents pending.

INDEX

A

AC *see power*
accessories 2, 3
adapter 2
aperture 16, 24

B

beep *see indicator*
blue *see indicator*
button 16

C

cable 4–8, 42, 43
communication 2, 3, 4–8, 9, 16,
23, 40–43
connector 16
pinout 40–43
power 2, 4–8
PowerLink 1, 42, 43
caution 4–8, 24, 45–47
CE 24
CodeGate .. 1, 10, 11, 18, 19, 20, 35
compliance 4–8, 24, 34, 45–47
configuration 28, 32, 42, 43, *see*
modes
connector 40–43
current 34
customer service 2, 29, 44, 51

D

DC *see power*
default 28, 35–39
depth of field 25, 26, 33

F

flash 19, 23

H

host 4–8, 18, 20–22, 28, 40–43

I

IBM 46xx *see interface*
indicator 33
audible 17–19, 23, 29–31
failure 17–19, 19, 29–31
visual 16, 17–19, 23, 29–31

interface 33, 40–43
IBM 46xx 5, 28, 35–39
Keyboard Wedge. 2, 6, 28, 35–39
Laser Emulation 4, 28, 35–39
Light Pen 4, 28, 35–39
OCIA 3, 5, 28, 35–39
RS232 2, 4, 28, 35–39
Stand-Alone Keyboard 2, 7, 28
USB 3, 8, 28, 35–39, 35–39
IR 27, 33

K

keyboard 28
Keyboard Wedge *see interface*

L

label 24
laser 33, 34, 45–47
Laser Emulation *see interface*
LED *see indicator*
Light Pen *see interface*

M

manual 2
modes 10, 20–22, 23, 35

N

notices 45–47

O

OCIA *see interface*

P

parameter 35–39
patent 48
PDF417 11, 26, 28
pinout 40–43
power.2, 4–8, 18, 19, 33, 34, 40–43
PowerLink 9, 16
protocol 28

R

razzberry *see indicator*
repair 44
RMA 44
RS232 32, 41, *see interface*

INDEX

S

- safety 45–47
- SELV 4–8
- software *see flash*
- specification
 - electrical 34
 - environmental 34
 - mechanical 33
 - operation 33
- speed 33
- stand 3, 10, 12–15, 35
- Stand-Alone Keyboard
see interface

T

- temperature 34
- test 32
- tone *see indicator*
- transformer *see power*
- troubleshooting 29–31

U

- UL 24
- USB *see interface*

V

- voltage 2, 34

W

- wall hook 12, 15
- warranty 29, 44
- white *see indicator*
- window 16, 24

Y

- yellow *see indicator*

Worldwide Headquarters

Metrologic Instruments, Inc.

90 Coles Road Blackwood, NJ 08012-4683

Email: info@metrologic.com • Tel: 856-228-8100

Fax: 856-228-6673 (Sales) • Fax: 856-228-1879 (Marketing) • Fax: 856-228-0653 (Legal/Finance)

Metrologic Companies

Adaptive Optics Associates (AOA)

Tel: 617-806-1400
Fax: 617-806-1899
Email: info@aoainc.com

Omniplanar

Tel: 856.537.6100
Fax: 856.537.6116
Email: info@omniplanar.com

Metrologic - The Americas

Headquarters

Tel: 1.856.537.6400
Fax: 1.856.537.6474
Email: info@us.metrologic.com

Metrologic Canada

Tel: 416.752.7190
Fax: 416.752.8060
Email: info@ca.metrologic.com

Metrologic do Brasil Ltda.

Tel: 55.11.5182.7273
Fax: 55.11.5182.7198
Email: info@sa.metrologic.com

Metrologic Mexico, S.A. DE C.V.

Tel: 55.5365.6247
Fax: 55.5362.2544
Email: info@mx.metrologic.com

Metrologic South America

Tel: 239.642.1958
Fax: 239.642.1959
Email: info@sa.metrologic.com

Metrologic - USA

Tel: 1.856.537.6400
Fax: 1.856.537.6474
Email: info@us.metrologic.com

Metrologic - EMEA

Headquarters

Tel: 49-89-89019-0
Fax: 49-89-89019-200
Email: info@europe.metrologic.com

Metrologic Eria France SA

Tel: +33 (0) 1 48.63.78.78
Fax: +33 (0) 1 48.63.24.94
Email: info@fr.metrologic.com

Metrologic Eria Iberica, SL

Tel: +34 913 272 400
Fax: +34 913 273 829
Email: info@es.metrologic.com

Metrologic Russia

Tel: +7 095 730 7424
Fax: +7 095 730 7425
Email: info@ru.metrologic.com

Metrologic Instruments GmbH

Tel: 49-89-89019-0
Fax: 49-89-89019-200
Email: info@europe.metrologic.com

Metrologic Instruments Italia

Tel: +39 0 57 6511978 or +39 051 651 1978
Fax: +39 0 51 6521337
Email: info@it.metrologic.com

Metrologic Instruments Poland

Tel: +48 (22) 545 04 30
Fax: +48 (22) 545 04 31
Email: info@pl.metrologic.com

Metrologic Instruments UK Limited

Tel: +44 (0) 1256 365900
Fax: +44 (0) 1256 365955
Email: info@uk.metrologic.com

Metrologic - APAC

Headquarters

Tel : (65) 6842-7155
Fax : (65) 6842-7166
Email: info@sg.metrologic.com

Beijing Sales Office

Tel/Fax: 86 10 82253472
Email: info@cn.metrologic.com

Chengdu Sales Office

Tel/Fax: 86 28 86200109
Email: info@cn.metrologic.com

Guangzhou Sales Office

Tel: 86-20-38823476
Fax: 86-20-38823477
Email: info@cn.metrologic.com

India Sales Office

Tel: +91 80 51256718
Fax: +91 80 51256719
Email: info@in.metrologic.com

Korea Sales Office

Tel: 82-2-6205-5379
Fax: 82-2-3444-3980
Email: Scott.lee@kr.metrologic.com

Metrologic Asia (Pte) Ltd

Tel : (65) 6842-7155
Fax : (65) 6842-7166
Email: info@sg.metrologic.com

Metrologic Japan Co., Ltd.

Tel: 81-3-3839-8511
Fax: 81-3-3839-8519
Email: info@jp.metrologic.com

Metrologic Thailand

Tel: 661-814-2352
Email: tawan.jandang@th.metrologic.com

MTLG Auto ID Instruments (Shanghai) Co., Ltd

Tel: 86-21-58692780
Fax: 86-21-58692782
Email: info@cn.metrologic.com

Suzhou Sales Office

Tel: 86-512-67622550
Fax: 86-512-67622560
Email: info@cn.metrologic.com

Taiwan Sales Office

Tel: 886-2-2351 0125
Email: john.cheng@tw.metrologic.com

May 2006 Version 01

Printed in the USA



00 - 02989D