

SOHO Wireless Internet Camera

User's Guide

Ver. WB2.1.0

TABLE OF CONTENTS

| | |
|---|-----------|
| ABOUT THIS GUIDE | 5 |
| INTRODUCTION | 6 |
| SYSTEM REQUIREMENT | 7 |
| WIRELESS INTERNET CAMERA..... | 7 |
| <i>Network:</i> | 7 |
| <i>Recommended PC or Notebook to Access the Wireless Internet</i> | |
| <i>Camera</i> | 7 |
| FEATURES AND BENEFITS | 9 |
| SIMPLE TO USE | 9 |
| SUPPORT VARIETY OF PLATFORMS..... | 10 |
| WEB CONFIGURATION..... | 10 |
| REMOTE UTILITY | 10 |
| BROAD RANGE OF APPLICATIONS..... | 11 |
| PHYSICAL DESCRIPTION..... | 12 |
| FRONT PANEL..... | 12 |
| <i>Power LED</i> | 13 |
| <i>Link LED</i> | 13 |
| REAR PANEL..... | 14 |
| <i>Network Cable Connector</i> | 14 |
| <i>DC Power Connector</i> | 14 |
| <i>Reset Button</i> | 15 |
| <i>Antenna Connector</i> | 15 |
| TOP PANEL..... | 16 |
| <i>Screw Hole</i> | 16 |
| BOTTOM PANEL..... | 17 |
| <i>Screw Hole</i> | 17 |

| | |
|---|-----------|
| UNPACKING THE WIRELESS INTERNET CAMERA | 18 |
| CONNECTING THE WIRELESS INTERNET CAMERA TO THE CAMERA STAND..... | 19 |
| HARDWARE INSTALLATION | 20 |
| 1 ATTACH WIRELESS ANTENNA..... | 20 |
| 2 CONNECT AN ETHERNET CABLE..... | 21 |
| 3 ATTACH THE EXTERNAL POWER SUPPLY | 21 |
| SECURITY | 22 |
| SOFTWARE INSTALLATION | 24 |
| WEB CONFIGURATION..... | 24 |
| MAIN MENU IMAGE..... | 26 |
| SYSTEM ADMINISTRATION..... | 27 |
| SYSTEM ADMINISTRATION..... | 27 |
| <i>System Administration – System</i> | 27 |
| <i>System Administration - Image</i> | 38 |
| <i>System Administration - Users</i> | 40 |
| <i>System Administration – DateTime</i> | 42 |
| System Administration – Upload..... | 44 |
| <i>System Administration – E-mail</i> | 47 |
| <i>System Administration - Information</i> | 49 |
| <i>System Administration - Tools</i> | 50 |
| VIEW IMAGE – ACTIVEX MODE | 51 |
| VIEW IMAGE – JAVA MODE..... | 53 |
| WIRELESS INTERNET CAMERA APPLICATION | 55 |
| APPLICATIONS..... | 56 |
| INTERNET CAMERA APPLICATION DIAGRAMS | 57 |
| <i>Home Applications</i> | 57 |
| <i>SOHO Applications</i> | 58 |
| IPVIEW SE APPLICATION | 59 |
| INSTALLATION..... | 59 |

| | |
|--|-----------|
| GETTING STARTED..... | 65 |
| IPVIEW SE..... | 65 |
| <i>IPView SE control panel</i> | 66 |
| <i>Minimize</i> | 67 |
| <i>Exit</i> | 67 |
| <i>Play</i> | 67 |
| <i>Scan</i> | 67 |
| <i>Combine</i> | 67 |
| <i>About</i> | 67 |
| HOW TO ADD A CAMERA..... | 68 |
| <i>Add Camera</i> | 68 |
| HOW TO CHANGE CAMERA..... | 74 |
| <i>Assign IP of New Camera</i> | 74 |
| HOW TO CONNECT / DISCONNECT THE IMAGE..... | 75 |
| <i>Connect the Image</i> | 75 |
| <i>Disconnect the Image</i> | 77 |
| HOW TO DELETE A CAMERA..... | 78 |
| <i>Erase Camera</i> | 78 |
| EXTRA INFORMATION..... | 79 |
| <i>Extra Information</i> | 79 |
| HOW TO ADJUST THE PROPERTY SETTING..... | 80 |
| <i>System Configure</i> | 80 |
| <i>Camera Configure</i> | 82 |
| <i>Camera Setting</i> | 82 |
| <i>Motion Setting</i> | 83 |
| <i>Update Firmware</i> | 85 |
| HOW TO ADJUST THE RECORDING SETTING..... | 86 |
| <i>Motion Record</i> | 86 |
| <i>Schedule Record</i> | 86 |
| <i>Manual Record</i> | 86 |
| APPENDIX | 87 |
| A FREQUENTLY ASKED QUESTIONS..... | 87 |
| B PING YOUR IP ADDRESS..... | 90 |
| C TROUBLE SHOOTING..... | 91 |

| | |
|-------------------------------------|-----|
| D TIME ZONE TABLE..... | 95 |
| E XPLUG CONTROL INSTALLATION..... | 97 |
| F ADJUST INTERNET CAMERA FOCUS..... | 101 |
| G SPECIFICATION..... | 102 |
| H GLOSSARY OF TERMS..... | 105 |

ABOUT THIS GUIDE

This manual describes the Wireless Internet Camera, including a description of the features, as well as the installation procedures and web configuration. This manual also includes the operating procedures for the IPView SE application.

1

INTRODUCTION

Thank you for purchasing the Wireless Internet Camera, a camera device that can be connected directly to an Ethernet or Fast Ethernet network and also supported by the wireless transmission based on the IEEE 802.11b standard. Compared to the conventional PC Camera, the Wireless Internet Camera features a built-in CPU and web-based solutions that can provide a cost-effective solution to transmit real-time high-quality video images and sounds for monitoring. The Wireless Internet Camera can be managed remotely, accessed and controlled from any PC/Notebook over the Intranet or Internet via a web browser. The simple installation procedures and web-based interface allow you to integrate it into your network easily. With comprehensive applications supported, the Wireless Internet Camera is your best solution for remote monitor, high quality, and high performance video images.

2

SYSTEM REQUIREMENT

Wireless Internet Camera

Network:

Local Area Network: 10Base-T Ethernet or 100Base
TX Fast Ethernet

Wireless Local Area Network: IEEE 802.11b Wireless LAN

Recommended PC or Notebook to Access the Wireless Internet Camera

Web Browser:

System requirement:

| | |
|----------------------|------------------------------|
| CPU: | Pentium II, 266 MHz or above |
| Memory Size: | 32 MB (64 MB recommended) |
| VGA card resolution: | 800x600 or above |

- Internet Explorer 5.0 or above (ActiveX & JAVA Mode – Image View for Windows OS and JAVA Mode – Image View for other OS)
- Netscape 6.0 or above (JAVA Mode – Image View)

IPView SE Application:

Support OS: Win 98 SE, Win 2000, Win Me, Win XP

System requirement for IPView SE:

| | |
|----------------------|-------------------------------|
| CPU: | Pentium III, 450 MHz or above |
| Memory Size: | 128 MB (256 MB recommended) |
| VGA card resolution: | 800x600 or above |

3

FEATURES AND BENEFITS

This section describes the features and benefits of the Wireless Internet Camera

Simple To Use

The Wireless Internet Camera is a standalone system with built-in CPU requiring no special hardware or software such as PC frame grabber cards. The Wireless Internet Camera supports both ActiveX mode (for Internet Explorer users) and Java mode (for Internet Explorer and Netscape Navigator users). Therefore, all that is required is a web browser software such as Internet Explorer 5.0 or above or Netscape 6.0 or above. Just plug and view the picture from your Wireless Internet Camera with a valid IP Address.

Support Variety of Platforms

The Wireless Internet Camera supports TCP/IP networking, SMTP e-mail, HTTP and other Internet related protocols, and can be utilized in a mixed operating system environment such as Windows, Unix, and Mac. It can be integrated easily into other www/Intranet applications.

Web Configuration

Applying a standard web browser, the administrator can configure and manage the Wireless Internet Camera directly from its own web page via the Intranet or Internet. Up to 64 users name and password are permitted with privilege setting controlled by the administrator.

Remote Utility

The powerful IPView SE application assigns the administrator with a pre-defined user ID and password, allowing the administrator to modify the Wireless Internet Camera settings from the remote site via Intranet or Internet. When new firmware is available, you can also upgrade remotely over the network for added convenience. Users are also allowed to monitor the image, and take snapshots.

Broad Range of Applications

With today's high-speed Internet services, the Wireless Internet Camera can provide the ideal solution for live video images over the Intranet and Internet for remote monitoring. The Wireless Internet Camera allows remote access from a web browser for live image viewing and allows administrator to manage and control the Wireless Internet Camera anywhere and any time in the world. Apply the Wireless Internet Camera to monitor various objects and places such as homes, offices, banks, hospitals, child-care centers, amusement parks and other varieties of industrial and public monitoring. The Wireless Internet Camera can also be used for intruder detection; in addition, it can capture still images for archiving and many more applications.

4

PHYSICAL DESCRIPTION

This section describes the externally visible features of the Wireless Internet Camera.

Front Panel

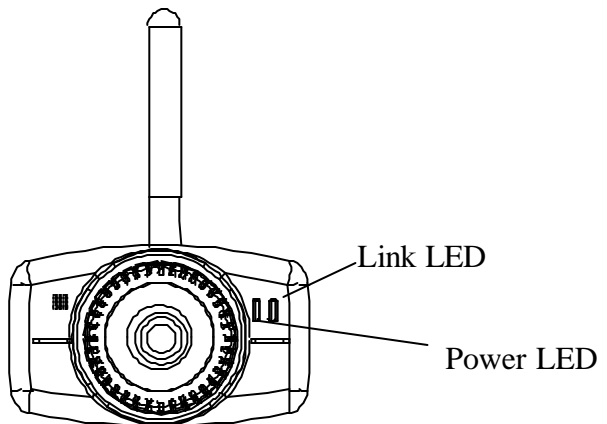

Power LED

The Power LED is positioned on the right side of the Wireless Internet Camera's lens while facing the Wireless Internet Camera.

A steady blue light confirms that the Wireless Internet Camera is powered on.

Link LED

The Link LED is positioned on the right side of the Wireless Internet Camera's lens while facing the Wireless Internet Camera. It is located right of the Power LED

A steady orange light confirms that the camera has good connection to LAN connectivity.

Dependent on the data traffic the LED will begin to flash to indicate that the Wireless Internet Camera is receiving/sending data from/to the network.

Rear Panel

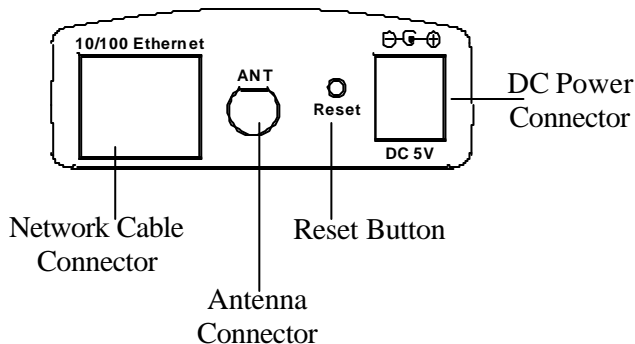

Network Cable Connector

The Wireless Internet Camera's rear panel features an RJ-45 connector for connections to 10Base-T Ethernet cabling or 100Base-TX Fast Ethernet cabling (which should be Category 5 twisted-pair cable). The port supports the NWay protocol, allowing the Wireless Internet Camera to automatically detect or negotiate the transmission speed of the network.

DC Power Connector

The DC power input connector is located on the Wireless Internet Camera's rear panel, and is labeled DC 5V with a single jack socket to supply power to the Wireless Internet Camera. Power

will be generated when the power supply is connected to a wall outlet.

Reset Button

Reset will be initiated when the reset button is pressed once, and Power LED begins to flash.

Factory Reset will be initiated when the reset button is pressed continuously for three seconds or when Power LED begins to light up. Release the reset button and the Power LED will begin to flash, indicating the Wireless Internet Camera is changing to factory reset. When factory reset is completed, the Wireless Internet Camera will be set to default on channel 11 and ESS-ID is set as “NULL String” (This default setting will let the Wireless Internet Camera connect to ANY access point on the infrastructure network). The IP address will also return to the default setting as 192.168.0.20.

Antenna Connector

There are two SMA type antenna connectors located on the rear panel of the Wireless Internet Camera, providing connection for two high sensitivity antenna included in the package.

Top Panel

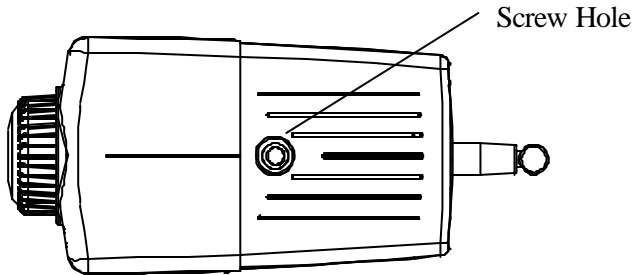

Screw Hole

Located on the top panel of the Wireless Internet Camera, the screw hole is used to connect the camera stand onto the Wireless Internet Camera by attaching the screw head on the camera stand into the screw hole of the Wireless Internet Camera.

Bottom Panel

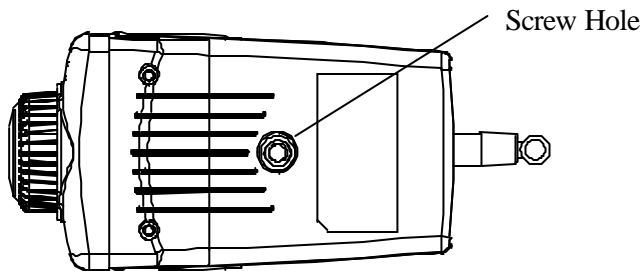

Screw Hole

Located on the bottom panel of the Wireless Internet Camera, the screw hole is used to connect the camera stand onto the Wireless Internet Camera by attaching the screw head on the camera stand into the screw hole of the Wireless Internet Camera.

5

UNPACKING THE WIRELESS INTERNET CAMERA

Carefully remove all items from the package. In addition to this User's Guide, be certain that you have:

- One Wireless Internet Camera
- One External Wireless Antenna
- One Installation CD-ROM
- One Quick Installation Guide
- One DC power adapter suitable for your country's electric power
- One Camera Stand
- One RJ-45 Ethernet Cable

If any item is missing, or if you find any damage or mismatch, promptly contact your dealer for assistance.

Connecting the Wireless Internet Camera to the Camera Stand

The Wireless Internet Camera comes with a camera stand (optional) with a swivel ball screw head that can be attached to the Wireless Internet Camera's bottom screw hole. Attach the camera stand to the Wireless Internet Camera and station it for your application. There are three holes located in the base of the camera stand allowing the Wireless Internet Camera to be mounted on the ceiling or any wall securely.

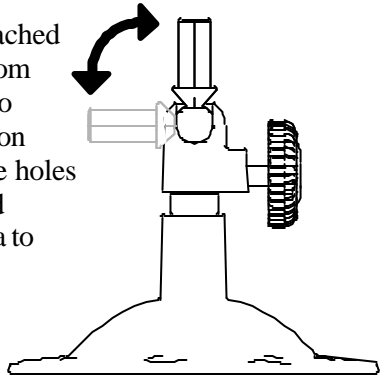

6

HARDWARE INSTALLATION

This section describes the Hardware installation procedure for the Wireless Internet Camera.

1 Attach Wireless Antenna

From the rear panel of the Wireless Internet Camera, screw the external Antenna that came with the Wireless Internet Camera into the antenna connector.

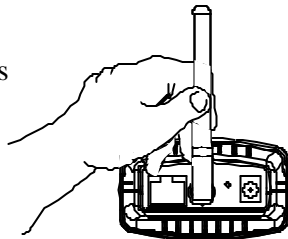

2 Connect an Ethernet cable

Connect an Ethernet cable to the network cable connector located on the Wireless Internet Camera's rear panel, and then attach it to the network.

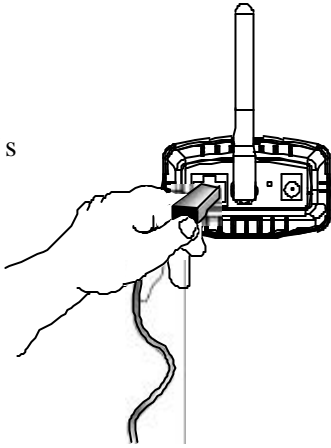

3 Attach the external power supply

Attach the external power supply to the DC power input connector located on Wireless Internet Camera's rear panel, and then connect it to your local power supply.

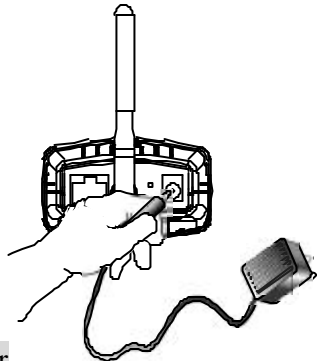

Note:

Confirm power source is supplied from the LED indicators label Power on the Wireless Internet Camera is illuminated.

7

SECURITY

To ensure the highest security and prevent unauthorized usage of the Wireless Internet Camera the Administrator has the exclusive privilege to access the System Administration for settings and control requirements to allow users the level of entry and authorize the privileges for all users. The Wireless Internet Camera supports multi-level password protection and access to the Wireless Internet Camera is strictly restricted to defined the user who has a "User Name" and "User Password" that is assigned by the Administrator.

Administrator can release a public user name and password so when remote users access the Wireless Internet Camera they will have the right to view the image transmitted by the Wireless Internet Camera.

Note:

Since the default settings are Null String, it is highly recommended to set the "Admin ID" and "Admin Password" when you are the first time to use the Wireless Internet Camera. Once the ID and Password are defined, only the administrator has the access to management the Wireless Internet Camera. This procedure should be done as soon as possible since the security

features with the Wireless Internet Camera will not be enabled until the "Admin ID" and "Admin Password" is defined.

8

SOFTWARE INSTALLATION

This section describes the Software installation procedure of the Wireless Internet Camera for Web Configuration and IPView SE application.

Web Configuration

The Wireless Internet Camera must be configured through its built-in Web-based Configuration.

Extensive knowledge of LAN will be helpful in setting up the Wireless Internet Camera

From the web browser, enter the default IP address to access the Welcome screen of the Wireless Internet Camera. To configure your Wireless Internet Camera, type `http://192.168.0.20` in the

address box. The number is the default IP address of your Wireless Internet Camera. Then, press [Enter].

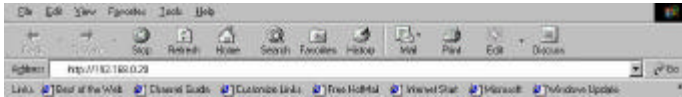

Note:

The PC's IP address must correspond with the Wireless Internet Camera's IP address in the same segment for the two devices to communicate.

Main Menu Image

After the default IP address is entered from the browser, the Wireless Internet Camera Welcome screen will appear with a still image. There will be three options to choose from to set-up and view your Wireless Internet Camera, including:

- View Image – ActiveX Mode
- View Image – Java Mode
- System Administration



System Administration

Click “**System Administration**” from the Welcome screen to access the settings required for the Wireless Internet Camera.

There will be several options in the System menu bar to choose from to set your Wireless Internet Camera, including:

- System
- Image
- Users
- DateTime
- Upload
- E-mail
- Information
- Tools

System Administration

System Administration – System

The System menu contains commands for settings that are required for inputting key details to set-up the Wireless Internet Camera for operation.

Click "**System**" in the system administration menu bar, and the System screen will appear as illustrated below:

| | | | | | | | | |
|----------------|---|--|-----------|--------|--------|-------------|-------|-------------|
| System | Image | User | Date Time | Upload | E-mail | Information | Tools | Home |
| System | | | | | | | | |
| Camera Name | <input type="text" value="CS-051503"/> | | | | | | | |
| Location | <input type="text"/> | | | | | | | |
| Admin | Admin ID | <input type="text"/> | | | | | | |
| | Admin Password | <input type="password"/> | | | | | | |
| | Confirm Password | <input type="password"/> | | | | | | |
| IP Assignment | <input checked="" type="radio"/> Manually Assign | | | | | | | |
| | IP Address | <input type="text" value="192.168.0.20"/> | | | | | | |
| | Subnet Mask | <input type="text" value="255.255.255.0"/> | | | | | | |
| | Default Gateway | <input type="text" value="0.0.0.0"/> | | | | | | |
| | <input type="radio"/> Assign Automatically Using | | | | | | | |
| | <input type="radio"/> RARP | | | | | | | |
| | <input type="radio"/> BOOTP | | | | | | | |
| | <input type="radio"/> DHCP | | | | | | | |
| | <input type="radio"/> PPPoE | | | | | | | |
| | Service Name | <input type="text"/> | | | | | | |
| | User ID | <input type="text"/> | | | | | | |
| | Password | <input type="password"/> | | | | | | |
| DNS IP Address | 1 | <input type="text" value="0.0.0.0"/> | | | | | | |
| | 2 | <input type="text" value="0.0.0.0"/> | | | | | | |
| Dynamic DNS | <input type="radio"/> Yes <input checked="" type="radio"/> No | | | | | | | |
| | Service Provider | <input type="text" value="DynDNS.org"/> | | | | | | |
| | Host Name | <input type="text"/> | | | | | | |
| | User Name | <input type="text"/> | | | | | | |
| | Password | <input type="password"/> | | | | | | |

Click **“Home”** to return to Welcome Screen

| | | |
|--------------------|---|---|
| Wireless Interface | Connection Mode | <input checked="" type="radio"/> Infrastructure <input type="radio"/> Adhoc |
| | Network Name | <input type="text"/> (ESS-ID) |
| | Wireless Channel | <input type="text" value="11"/> |
| | WEP Key Encryption | <input checked="" type="radio"/> Disable <input type="radio"/> 64 bits <input type="radio"/> 128 bits |
| | WEP Key | <input type="text"/> <input type="radio"/> ASCII <input type="radio"/> HEX |
| | Confirm WEP Key | <input type="text"/> |
| | LED Control | <input checked="" type="radio"/> Normal <input type="radio"/> OFF <input type="radio"/> Dummy |
| | Loading ActiveX from | <input type="text"/> |
| | Open Second Port | <input type="radio"/> Yes <input checked="" type="radio"/> No |
| | | 1: Web Server - Default 80 <input type="text"/> |
| | 2: Transfer Image - Default 8481 <input type="text"/> | |
| | <input type="button" value="Save"/> <input type="button" value="Cancel"/> | |

Camera Name:

This field is used to enter a descriptive name for the device.

The default setting for the Camera Name is CS-xxxxxx, where xxxxxx is the last six digit of the MAC Address. The maximum length is 32 (Printable ASCII).

Location:

This field is used to enter a descriptive name for the location used by the Wireless Internet Camera.

Admin:

This field is used to enter the Administrator ID along with the password to access the System Administration settings. Be sure to enter the password twice to confirm the details once in the Admin Password field and again in the Confirm Password field.

The default setting for Admin is blank space (Null String), and you need to key in the Admin ID with a maximum length of 12 (Printable ASCII) characters and enter the Admin Password with a maximum length of 8 (Printable ASCII) characters.

It is highly recommended to set the Admin ID and Admin Password as soon as possible to enable security option for the Wireless Internet Camera to function.

IP Assignment:

Important Information

Access to the Wireless Internet Camera is done through assigning a proper IP address. Please make sure to use a vacant IP address when you assign the IP address for the Wireless Internet Camera. This will prevent errors from occurring if the IP address is overlapped.

There are two options to select from the IP Assignment:
Manually Assign or **Assign Automatically Using**.

Manually Assign

You can click “**Manually Assign**” and directly enter the IP address.

The default settings are as follows:

- Default IP – 192.168.0.20
- Subnet Mask – 255.255.255.0
- Default Gateway – 0.0.0.0

Assign Automatically Using

If your network is using RARP, BOOTP or DHCP server, you can click **“Assign Automatically Using”** and then click **“RARP”**, **“BOOTP”** or **“DHCP”**. Under this setting the Wireless Internet Camera will automatically assign an IP address from RARP, BOOTP or DHCP server. Every time when the camera starts up, please make sure that the DHCP server is set to assign a static IP address to your camera.

If your application requires direct connection from an ADSL modem through the Wireless Internet Camera’s RJ-45 LAN port, and you also have an ISP PPPoE account, click **“PPPoE”** option and enter the Service Name, User ID and Password into the respective fields. The Wireless Internet Camera will get an IP address from the ISP as starting up.

DNS IP Address:

DNS (Domain Name System) server is an Internet service that translates domain names into IP addresses. Enter at least one DNS IP Address.

Dynamic DNS:

The Dynamic DNS service allows you to alias a dynamic IP address to a static hostname in any of the domains, allowing your computer to be more easily accessed from various locations on the Internet.

Wireless Interface:

Connection Mode:

Use the Connection Mode to determine the type of wireless communication for the Wireless Internet Camera. There are three choices of **Infrastructure mode**, and **Adhoc mode**. The default setting for the Connection Mode is Infrastructure.

Network Name:

This field is used to setup which wireless network (ESS-ID Extended Service Set ID) the Wireless Internet Camera is to be connected for communication. The ESS-ID is a unique identifier shared among all points in a wireless network environment.

The default Network Name is blank space (NULL String), and this default setting will let the Wireless Internet Camera connect to ANY access point under the infrastructure network mode.

To connect the Wireless Internet Camera to a specific access point on the network, please make sure to set the ESS-ID of the Wireless Internet Camera to correspond with the access point's ESS-ID for communication. Type any string up to 32 characters long (spaces, symbols, and punctuation are not allowed) in the Network Name box.

To connect the Wireless Internet Camera to an Ad-hoc wireless workgroup, please make sure to set the same wireless channel and ESS-ID to match with the PC/Notebook wireless channel and ESS-ID for direct wireless communication under the Ad-hoc wireless workgroup.

Wireless Channel:

The pull down menu provides the wireless channel for communication. A "channel" is a range of frequencies to be used in communication between the Wireless Internet Camera and Access Point in infrastructure mode or the Wireless Internet Camera and PC/Notebook in Ad-hoc mode. Select the appropriate channel from the list provided depending on the regulatory region where the unit is sold. The default setting is at channel 11.

Encryption WEP Key:

Wireless network communications are easily intercepted. WEP (Wired Equivalent Privacy) is an encryption method specified by the IEEE 802.11b standard to make any intercepted communications extremely difficult to interpret by unauthorized parties.

To enable WEP Encryption, you should decide which WEP key format will be applied first. Click the ASCII or HEX check box to select input format as ASCII format or HEX format, and then input WEP key. To confirm the WEP key, you must enter the data once again in the Confirm WEP Key field.

ASCII input format:

ASCII format causes each character you type to be interpreted as an eight-bit value. All unaccented upper- and lower-case Western European characters that can be input through your keyboard's typing zone are valid. To setup 64-bit WEP key, input 5 ASCII characters, for example, '12345'. To setup 128-bit WEP key, input 13 ASCII characters, for example, '1234567890123'. These character counts result in bit counts of 40 and 104, respectively; the Wireless Internet Camera will automatically pad your input to a bit count of 64 or 128.

HEX input format:

Hex format causes each pair of characters you type to be interpreted as an eight-bit value in hexadecimal (base 16) notation. Only the digits 0 through 9 and the letters A through F (in upper or lower case) are valid. To setup 64-bit WEP key, input 10 HEX format, for example, '3132333435', this is the same with ASCII input '12345'. To setup 128-bit WEP key, input 26 HEX format, for example, '31323334353637383930313233', this is the same with ASCII input '1234567890123'. These character counts result in bit counts of 40 and 104, respectively; the Wireless Internet Camera will automatically pad your input to a bit count of 64 or 128.

On the Confirm WEP Key field, input the same characters as the Encryption Code field.

Make sure the Encryption Code is the same with the access point's encryption code that the Wireless Internet Camera is to be connected under Infrastructure mode. Your PC/Notebook's encryption code also needs to be setup the same with the Wireless Internet Camera's encryption code under either Infrastructure mode or Ad-hoc mode.

The default setting for the Encryption Key is Disable therefore, to secure the wireless transmission be sure to Enable the Encryption Key by entering the relevant data.

Note:

Carefully input Encryption Code, any error setting will cause communication link to fail.

LED Control:

The LED control allows user to setup the LED illumination as desired. This feature provides the flexibility when surveillance activity is ON.

There are three options as follows:

- Normal –
 - Power** - Steady On of the LED indicator.
 - Link** - Steady On of the LED indicator. When WLAN activity is present the LED indicator will flash steadily.
- OFF –
 - Power** - LED indicator is off
 - Link** – LED indicator is off
- Dummy –
 - Power** - Steady On of the LED indicator.
 - Link** - Steady On of the LED indicator with random flashing.

The default setting for the LED control is at Normal. When you have configured the LED control, the correct illumination will be set after 1 minute.

Note:

This function is built-in to the LED indicators to add extra capabilities. The three options allow the Administrator to configure and camouflage the illumination for the LED indicator to falsify the monitoring status. In Normal Mode, the LED indicator functions normally. Under Off Mode, the LED indicators are both off; however, it is still monitoring the activity. In Dummy Mode, the LED indicators operate in monitoring condition but monitoring activity is off or on.

Loading ActiveX From:

This field is used to specify the location of Xplug Control (ActiveX) plug-in program. Enter the information as required in .ocx format, for example:

<http://www.<your company>.com/xplug.ocx>, where <your company> must be replaced with your company's DNS server.

Or it can be installed from the CD come with the internet camera.

Open Second Port:

The Web Server field allows settings to open a second port for the Wireless Internet Camera. This will permit users IP Sharing Gateways to support multiple Wireless Internet Cameras. By default, Port 80 is always opened for the Wireless Internet Camera Web Server access. Select “Yes” and input the second port value.

For example: If you have 5 Internet Camera to be installed, each with an IP address from

192.168.0.101

192.168.0.102

192.168.0.103

192.168.0.104

192.168.0.105

You can open the second port for each Internet Camera from port 81 to Port 85 as illustrated below:

Internet Camera 1 – IP 192.168.0.101, second web port 81

Internet Camera 2 – IP 192.168.0.102, second web port 82

Internet Camera 3 – IP 192.168.0.103, second web port 83

Internet Camera 4 – IP 192.168.0.104, second web port 84

Internet Camera 5 – IP 192.168.0.105, second web port 85

You also need to setup your DSL gateway for Port Mapping.

Port 81 map to 192.168.0.101

Port 82 map to 192.168.0.102

Port 83 map to 192.168.0.103

Port 84 map to 192.168.0.104

Port 85 map to 192.168.0.105

The Transfer Image field allows settings to open a second port for the Wireless Internet Camera to transfer images. The default Port 8481 is open image transfer and you can define a second port similar to the above.

Save/Cancel:

After making sure all settings in the System are correct, click the **“Save”** button to store the settings for the Wireless Internet Camera. You can alternatively click the **“Cancel”** button to restore all settings to the values last saved to or retrieved from the Wireless Internet Camera.

System Administration - Image

Image menu in the system administration contains commands to provide the settings for the images captured by the Wireless Internet Camera.

Click **“Image”** in the system administration menu bar and the Image screen will appear as illustrated below:

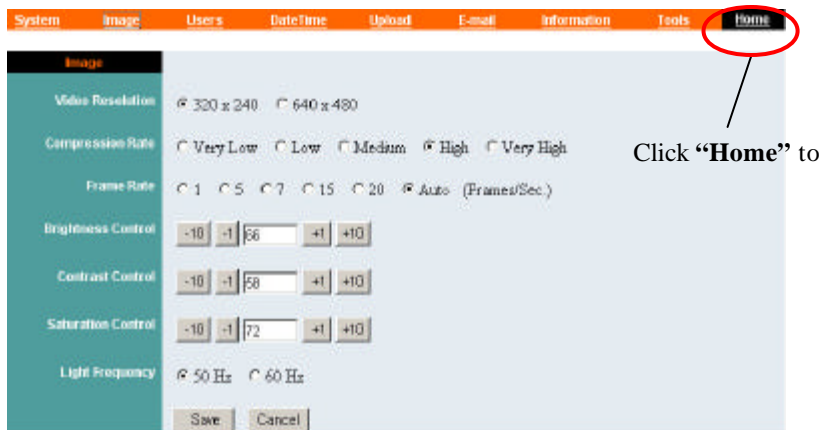

Video Resolution:

Select the desired video resolution format ranging from 320x240 (default) to 640x480

Compression Rate:

Select the desired compression rate with five levels from very low to very high. Higher video compression rate will generate more compact file size with less video quality and vise-versa. The default setting is Medium.

Frame Rate:

Select the frame rate desired with default setting at Auto for optimal frame rate.

Brightness Control:

Adjust the brightness level with default setting at 64.

Contrast Control:

Adjust the contrast level with default setting at 64.

Saturation Control:

Adjust the saturation with default setting at 64.

Light Frequency:

Adjust the light frequency to suit your area of operation from the options either 50 Hz or 60 Hz (default).

Note:

50 Hz and 60 Hz variants are available to accommodate the different light frequency found in USA (60 Hz) and Europe (50 Hz) for the Wireless Internet Camera to ensure better image quality.

Save/Cancel:

After making sure all settings in the Image are correct, click the “**Save**” button to store the settings for the Wireless Internet Camera. You can alternatively click the “**Cancel**” button to restore all settings to the values last saved to or retrieved from the Wireless Internet Camera.

System Administration - Users

The User options menu contains commands to allow the system administrator to assign legal users who are permitted to monitor the Wireless Internet Camera from the remote site.

Click “Users” in the system administration menu bar and the Users screen will appear as illustrated below:



Add User:

User Name:

Enter the user name in this field.

A maximum of 64 users names are allowed, however each users name must be different. Each user name can be used as a group given the password for example, if the User Name is “Guest” and the User Password is “Guest” anyone can access the Wireless Internet Camera with these details used as a group of users under the User Name Guest. The maximum length for the User Name is 12 (Printable ASCII).

User Password:

Enter the user’s password assigned by the administrator. The maximum password length is 8 (Printable ASCII).

Upload/E-mail Image :

The administrator has the authority to give permission for the privilege to control the Upload/E-mail Image Control to the users by selecting “Yes” or “No” to activate the Upload/E-mail Image.

To add a new users name input the necessary information first and click the “Add” button.

Delete User:

Select the user you wish to delete from the pull down menu and click the “delete” button.

Important Information

Once the administrator has configured the Internet Camera Users, any user will be asked to enter a login password to access the video image from the Wireless Internet Camera. The password dialog box is illustrated below.



System Administration – DateTime

The DateTime menu contains commands for setting the Wireless Internet Camera's time and date requirements to provide correct information to users who might be thousands of miles away in the remote site. There are two options to select from the DateTime menu bar either Synchronized with Time Server or Set Manually.

Click **“DateTime”** in the system administration menu bar and the DateTime screen will appear as illustrated below:

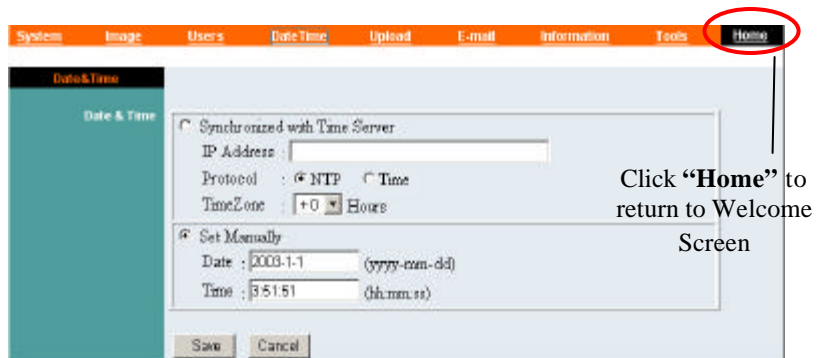

DateTime:

Select **“Synchronized with Time Server”** and the time will be based on GMT setting. The time will be synchronized every 10 minutes. This is also the default setting for the Wireless Internet Camera.

IP Address:

Enter the IP Address of the Time Server in this field.

Protocol:

Two options of NTP or Time are available for your selection to link with the Time Server. The default setting is NTP.

TimeZone:

The system administrator must select the time zone for the region.

Please refer to the appendix for the time zone selection table.

To set the Date Time manually, select **“Set Manually”** and the system administrator must enter the Date and Time in the respective field manually.

Note:

When you select Set Manually, every time when the Wireless Internet Camera is powered off and on, you must re-enter the details once again due to time lost.

Save/Cancel:

After making sure all settings in the DateTime are correct, click the **“Save”** button to store the settings for the Wireless Internet Camera. You can alternatively click the **“Cancel”** button to restore all settings to the values last saved to or retrieved from the Wireless Internet Camera.

System Administration – Upload

The Upload menu contains the commands for FTP server, time schedule and manual operation settings.

Click **“Upload”** in the system administration menu bar, and the Upload screen will appear as below:

System Image Users DateTime Upload E-mail Information Tools **Home**

Upload

FTP Server

Host Address :

Port Number : 21 (Default is 21)

User Name :

Password :

Directory Path :

Passive Mode : Yes No

Time Schedule

Upload image to FTP server

Always

Schedule

Day : Mon Tue Wed Thu Fri Sat Sun

Time Period : Start : (hh:mm:ss)

Stop : (hh:mm:ss)

Image Frequency : Frames/Second

Seconds/Frame

Base File Name :

File : Overwrite

Date/Time Suffix

Sequence Number Suffix Up to 1024

Manual Operation

Upload image to FTP server

Base File Name :

File : Overwrite

Date/Time Suffix

Sequence Number Suffix Up to 1024

Save Cancel

Click **“Home”** t
return to Home Sci

There are three options to proceed in the Upload screen, including **FTP Server**, **Time Schedule** and **Manual Operation**.

FTP Server:

There are six basic settings for your FTP server.

- **Host Address:** The IP Address of the target FTP server.
- **Port Number:** The standard port number for the FTP server is Port 21, and it's also the default setting. If the FTP server uses a specific port, please confirm the IT manager.
- **User Name:** Enter the user name in this field.
- **Password:** Enter the user password in this field to login the FTP server.
- **Directory Path:** Enter an existing folder name in this field, and the images will be uploaded to the given folder.
- **Passive Mode:** This function depends on your FTP server. Please check with your IT manager if the FTP server uses passive mode. The default setting is '*No*'.

Time Schedule:

Select "**Upload image to FTP server**" and enter the relevant information, such as the schedule, image frequency and base file name.

- **Schedule:** You can 1.) Choose *Always* to always upload the images to FTP server, or 2.) Set the *Schedule* to

manage the uploading task. In the Schedule option, you can set the *Day* and *Time Period* option.

- **Image Frequency:** There are two ways to set the image frequency: 1.) Set *Auto/1/2/3* frames per second, or 2.) Set the time in seconds for every frame.
- **Base File Name:** Enter the file name to make sure that the images could be saved as the base file name.
- **File:** Since you may not upload only one image to the FTP server, you can choose the filing rule, including *Overwrite*, *Date/Time Suffix*, and set up the *Sequence Number*.

Manual Operation: When you click the upload “Image” button in view image screen, it will start to upload the image. The setting refers to “**Base File Name**” and “**File**” information above.

Save/Cancel:

After making sure all settings in the System are correct, click the “**Save**” button to store the settings for the Internet Camera. You can alternatively click the “**Cancel**” button to restore all settings to the latest saved values or retrieve the settings from Internet Camera.

System Administration – E-mail

The E-mail menu contains the commands for E-mail account, time schedule and manual operation settings.

Click “**E-mail**” in the system administration menu bar, and the setting screen will appear as below:

Click “**Home**” to return to Home Screen

Enter the relevant information, such as the SMPT Server Address, Sender e-mail Address, Receiver e-mail Address, User Name and Password.

Then active sending e-mail by selecting “**Enable e-mail Image**” in enter “Time schedule” or “Manual Operation”.

- **SMTP** (Simple Mail Transfer Protocol) is a protocol for sending e-mail messages between servers you need to input the mail server address in this field.
- **Sender e-mail** is the e-mail address of the user who will send the e-mail.
- **Receiver e-mail** is the e-mail address of the user who will receive the e-mail.
- **User Name** : Enter the user name in this field.
- **Password**: Enter the user password in this field to login receiver' s mail server

Time Schedule:

To set schedule to send e-mail.

“Interval”: Define time interval between two images sent.

Manual Operation:

When you click the E-mail image button in view image screen, it will start to e-mail image.

“Interval”: To define time interval between two images sent.

Save/Cancel:

After making sure all settings in the System are correct, click the **“Save”** button to store the settings for the Wireless Internet Camera. You can alternatively click the **“Cancel”** button to restore all settings to the values last saved to or retrieved from the Wireless Internet Camera.

System Administration - Information

The Information menu contains commands for displaying information about the Wireless Internet Camera.

Click **“Information”** in the system administration menu bar and the Information screen will appear as illustrated below:



The screenshot shows a system administration interface. At the top is a menu bar with the following items: System, Image, Users, DateTime, Upload, E-mail, Information, Tests, and Home. The 'Home' button is circled in red. Below the menu bar is the 'Information' screen, which displays the following data:

| Information | |
|------------------|--------------------------|
| Model | Wireless Internet Camera |
| Firmware Version | 2.20 (2003-10-25) |
| Mac Address | 00 03 1B 09 23 BF |
| IP Address | 192.168.0.20 |
| Diagnostics Code | 0000 |

Click **“Home”** to return to Welcome Screen

The Information table provides detailed information of the Wireless Internet Camera, such as the Model Name, Firmware Version, Mac Address, and IP Address.

System Administration - Tools

The Tools menu contains commands for restarting the Wireless Internet Camera.

Click **“Tools”** in the system administration menu bar and the Tools screen will appear as illustrated below:



Reset:

The Reset command restarts the Wireless Internet Camera just like turning the device off and on and saved settings are retained. The Reset panel contains the message “Do you really want to reset this device?” and a YES button. If you do not want to reset the Wireless Internet Camera, exit the panel without clicking YES; otherwise, click the **“YES”** button and the reset process will initiate.

Factory Reset:

A factory reset restarts the Wireless Internet Camera and returns all of its settings to their default values. The Factory Reset panel contains the message “Do you really want to factory reset this device?” and a YES button. If you do not want to carry out a factory reset command, exit the panel without clicking YES; otherwise, click the **“YES”** button and factory reset will be initiated.

Note:

The Network must be reconfigured after a Factory Reset.

Once the configuration is completed, click **“Home”** to return to the Welcome screen and select the desired Viewing Image either through ActiveX Mode or Java Mode as described in the next section.

Then, position the Wireless Internet Camera to the desired location appropriately for your purpose. Followed by adjustment of the Wireless Internet Camera focus, done manually by turning the lens clockwise or anti-clockwise to the desired image quality. *Please refer to the appendix for detailed information regarding Adjust Internet Camera Focus and Replacing the Lens.*

View Image – ActiveX Mode

To view video images from the browser, click **“View Image – ActiveX Mode”** from the welcome screen to access the video images from Internet Explorer as illustrated below:

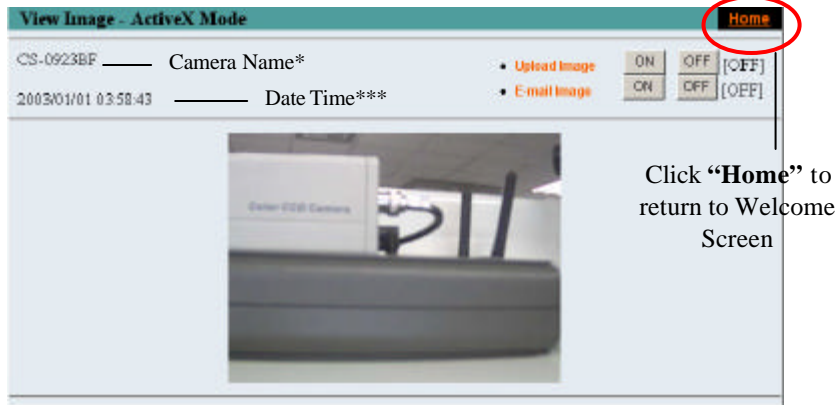

Camera Name* - The Camera name will be display when the Camera Name field is entered in the Web Configuration setting under “**System**”

Date/Time***- The date/time of the video server will show the date and time that come from time server or you set manually.

Note:

Please refer to the appendix on how to install ActiveX.

1. *Install to the Web Server*
2. *Install to your Local PC*

In the View Image – **ActiveX Mode**, you are allowed upload image and E-mail image options. Just click the desired selection “**ON**” or “**OFF**” to utilize the options for each of the functions.

Note 1:

Administrator has the authority to set the email image functions through the setting in the “E-mail” of System Administration menu bar.

Note 2:

The Administrator has the authority to allow the users to set the image upload functions through the setting in the “Upload” of System Administration menu bar.

View Image – Java Mode

Click “**View Image – Java Mode**” from the Welcome screen to access the video images from the Internet Explorer or Netscape browser as illustrated below:

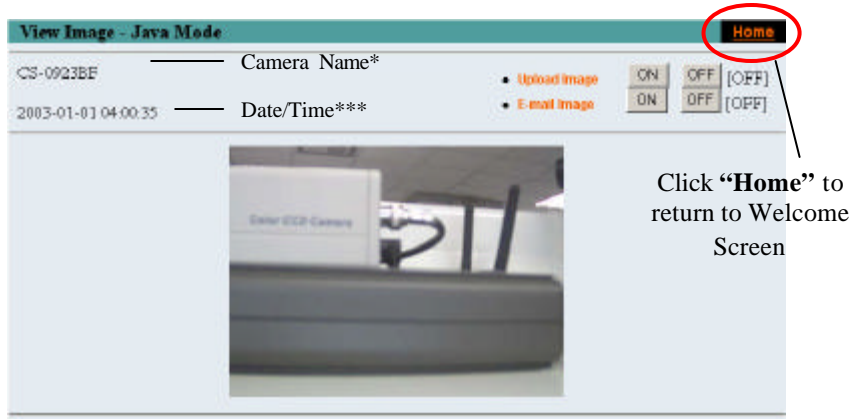

Camera Name* - The Camera name will display when the Camera Name field is entered in the Web Configuration setting under “**System**”

Date/Time*** - The date/time of the Wireless Internet Camera will show the date and time that come from time server or you set manually.

In the View Image – **ActiveX Mode**, you are allowed upload image and E-mail image options. Just click the desired selection “**ON**” or “**OFF**” to utilize the options for each of the functions.

Note 1:

Administrator has the authority to set the email image functions through the setting in the “E-mail” of System Administration menu bar.

Note 2:

The Administrator has the authority to allow the users to set up the image upload functions through the setting in the “Upload” of System Administration menu bar.

WIRELESS INTERNET CAMERA APPLICATION

The Wireless Internet Camera can be applied in wide variety of applications. With the built-in CPU, it can work as a standalone system that provides a web-based solution transmitting high quality video images and sounds for monitoring purposes. It can be managed remotely, accessed and controlled from any PC desktop over the Intranet or Internet via a web browser. With the easy installation procedure, real-time live images will be available. In addition, once the Wireless Internet Camera is installed coupled with the IPView SE application, you can further expand the scope of the Wireless Internet Camera.

The following section will provide the typical applications for the Wireless Internet Camera along with the IPView SE application, and also includes some basic knowledge to assist in the installation and configuration of the Wireless Internet Camera.

Applications

- Monitoring of local and remote places and objects such as construction sites, hospitals, amusement parks, schools and day-care centers through the use of a web browser.
- Capture single frame images from the IPView SE application.
- Configure the camera to upload image or send-mail messages with a single frame image.

Internet Camera Application Diagrams

Home Applications

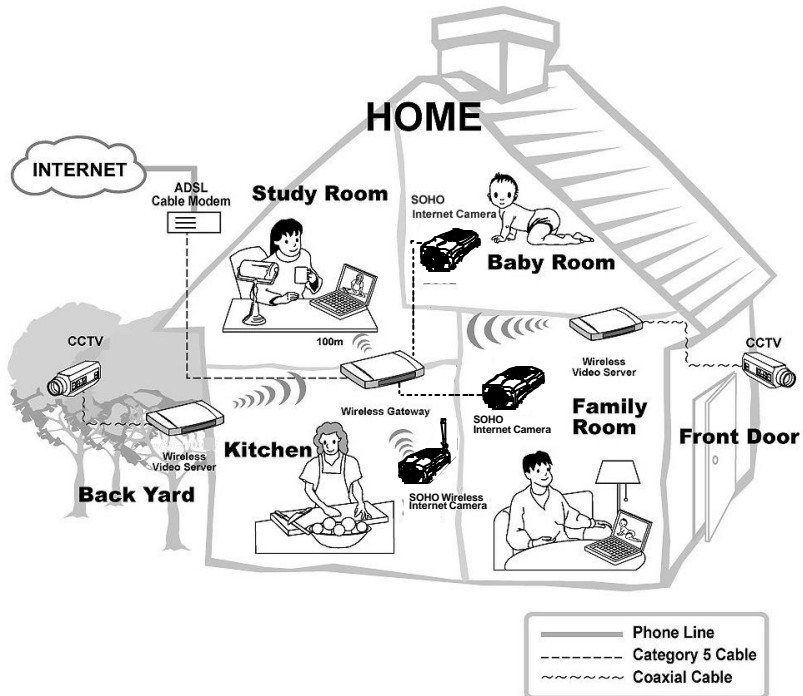

SOHO Applications

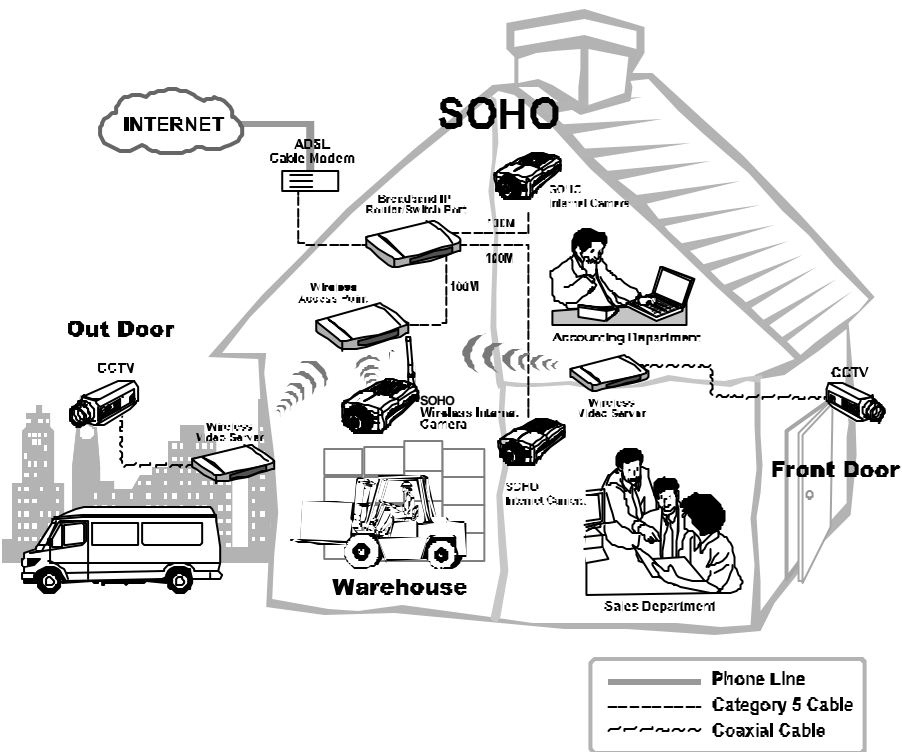

10

IPVIEW SE APPLICATION

Installation

Insert the CD-ROM into the CD-ROM drive to initiate the auto-run program. Once completed, a menu screen will appear as below:



To install the IPView SE application click the **"IPView SE"** button to activate the installation procedure for the application program.

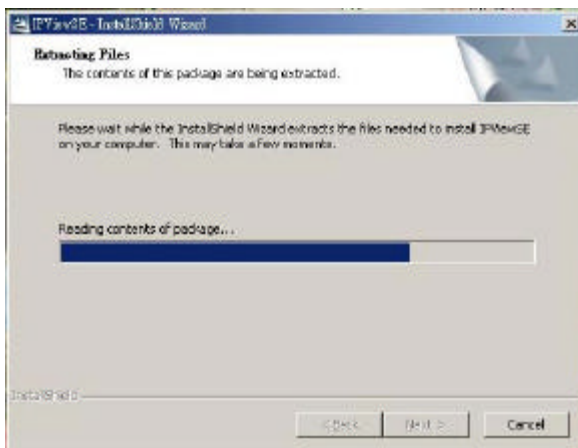

Once executed, you will be asked to select the desired language. Select the language you want and click **"OK"** to continue.

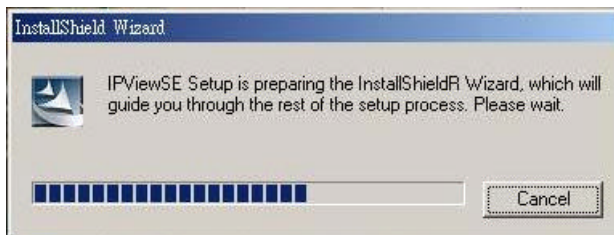

The Welcome screen will appear as below. Click the “Next” button.

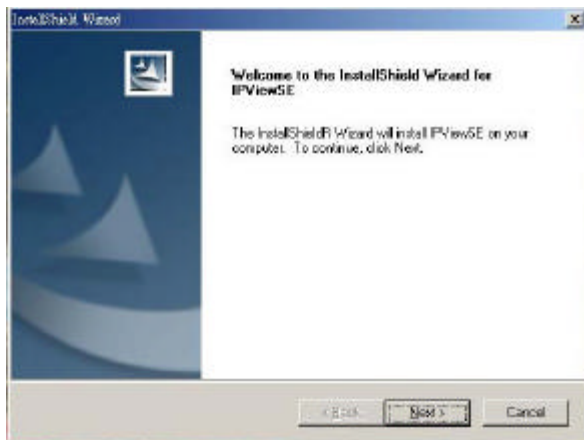

The License Agreement window will appear as below. Read the details carefully and click the “Yes” button.

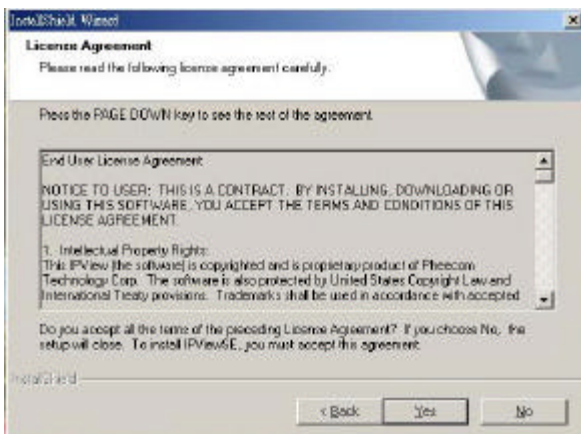

In the following window, you may click **“Next”** to accept the recommended destination location or click **“Browse”** to select another location. After specifying the desired destination location, click **“Next”**.

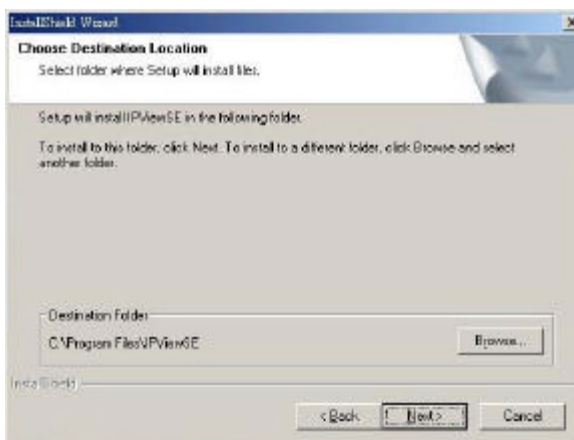

The following window allows you to select the folder where the IPView SE application will be located, click **“Next”** to continue.

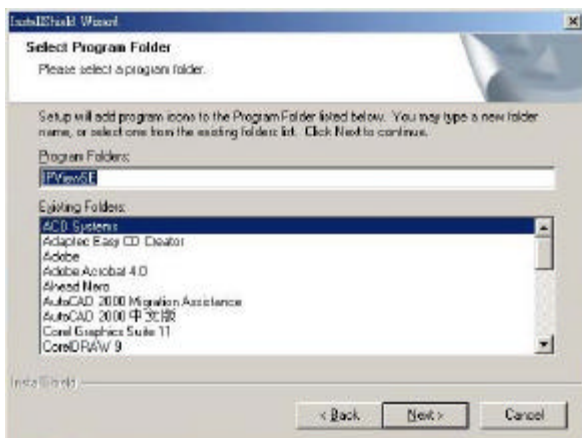

Please wait until one of the following two dialog boxes to appear. If the system has to restart, select “*Yes, I want to restart my computer now*” and click the “**Finish**” button to complete the installation procedure.

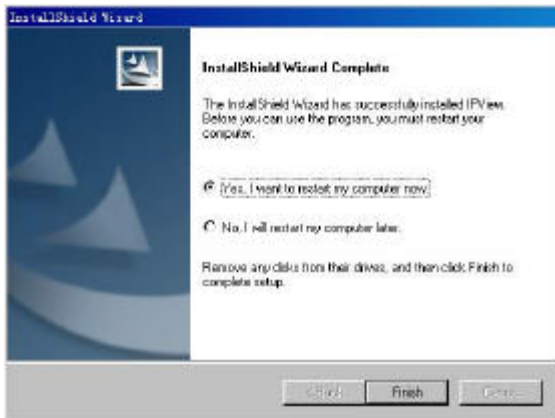

Otherwise, you may simply click the “**Finish**” button to complete the installation procedure

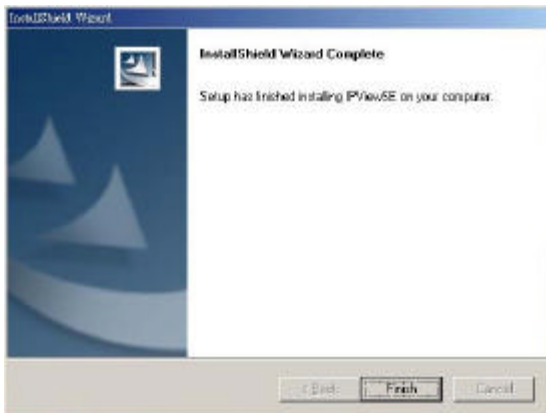

After successfully installing the IPView SE, the application program for the Wireless Internet Camera is automatically installed to \Programs\Files directory.

To start running the IPView SE, click **Start -> Programs -> IPView SE -> IPView SE**.

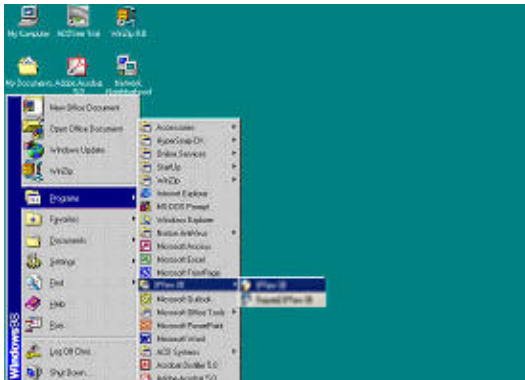

Once login, the IPView SE application is executed and the interface of IPView SE will appear in the default List View format as bellow:



GETTING STARTED

This section describes the operation of the IPView SE application with detailed procedures for using the application.

IPView SE

IPView SE is responsible for the management of preview, configuration, and searching of each camera.

It is designed with a user-friendly interface for ease of control and navigation requirements as illustrated below.

IPView SE control panel

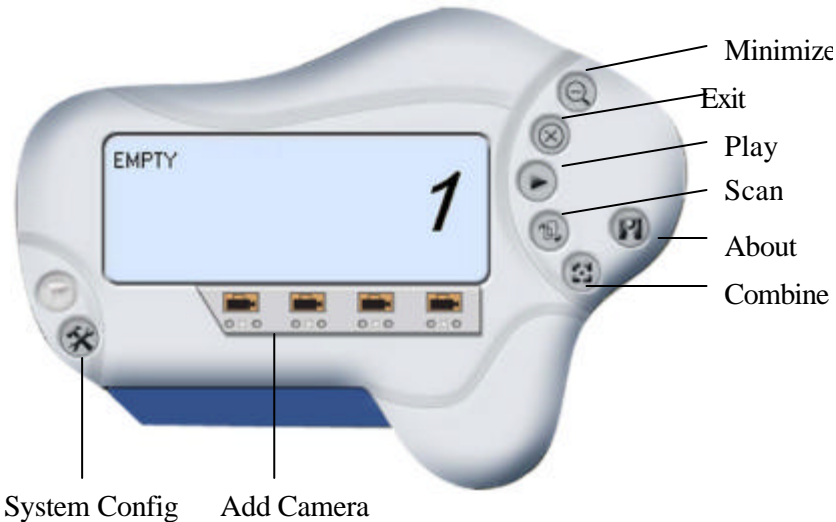



Minimize

To minimize the control panel.



Exit

To close IPView SE.



Play

To play back the recorded file.



Scan

To display for each camera one by one.



Combine

To combine all display windows in one.



About

To display the information of IPView SE.

How to Add a Camera



Add Camera

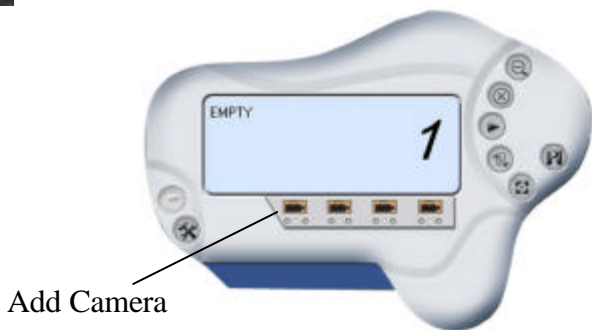

To add a new camera, click the **Add Camera** button. An **Add Camera** dialog box will appear as illustrated below.

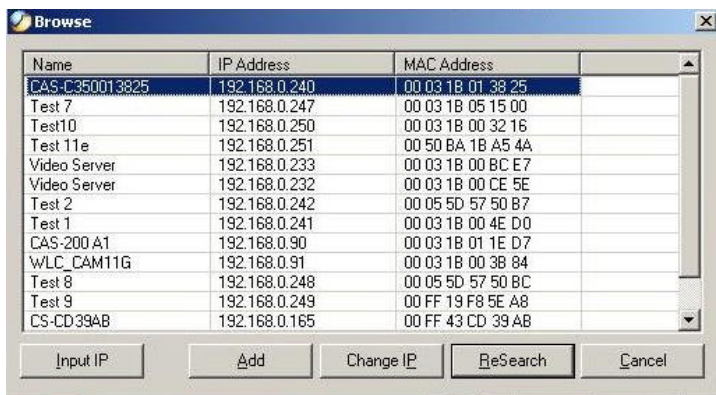

You must select the camera and click the **“Add”** button to add a new camera.

You can select the **“Input IP”** button, an **Input IP** dialog box will appear as illustrated below.

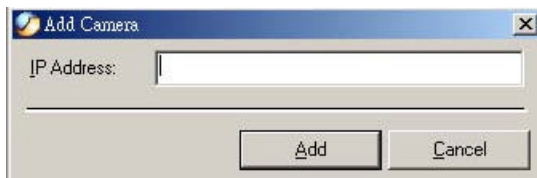

Enter the IP Address of the camera in the specified field and click the **“Add”** icon to add a new camera.

Note:

1. If you want to add a camera through the Internet, you must key in a physical IP Address.
2. When the camera is installed behind Gateway and the Open Second Port of camera/Port Forwarding of Gateway function is enabled, the Gateway IP address has to be entered with the Port Number as below:

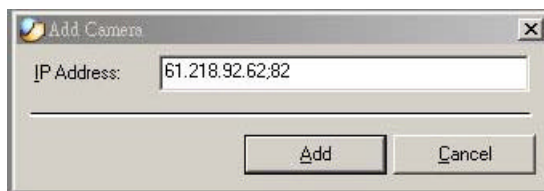

3. At the same time, the Gateway IP address can be replaced by URL as below:

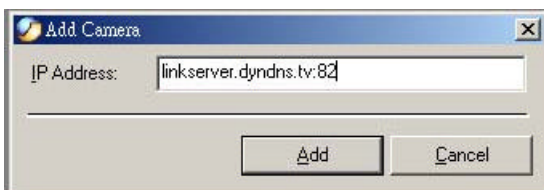

4. If you forget the IP Address that you want to add, a dialog box will appear to notify you of the error.



If you are unsure of the IP Address of the camera, you can click the **“Browse”** button, the **Browse Camera** dialog box will appear with a blank screen as illustrated below.

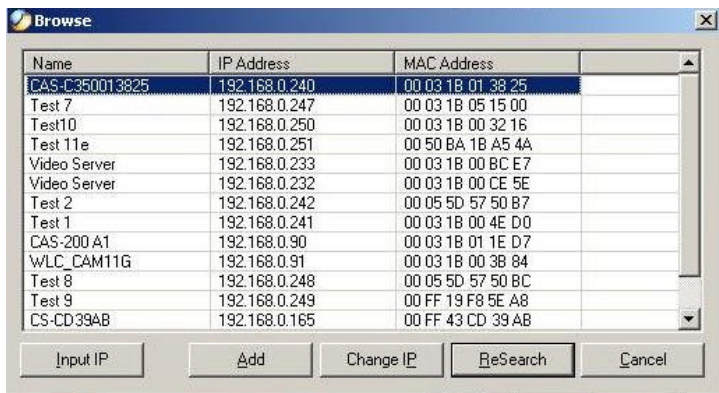

You must select the camera and click the **“Add”** button to add a new camera.

If the **Login Camera** dialog box appears, make sure to enter the correct **User Name** and **Password** and click the **“OK”** button. Then, the camera will be added into IPView SE in list format. If the **User Name** and **Password** is entered incorrectly, the camera will not be added into IPView SE.



The above dialog box will appear only if administrator has already set up the **User Name** and **Password** in the Web Configuration setting.

If you forget to highlight the camera you want to add, a dialog box will appear to notify you of the error.



Make sure to save any changes you have made to keep the information updated.

Note 2:

You are allowed to add only one camera at a time.

When the user add the Internet Camera, four icons will appear, including: “Assign IP to Camera”, “Connect/Disconnect”, “Erase”, “Extra Information”

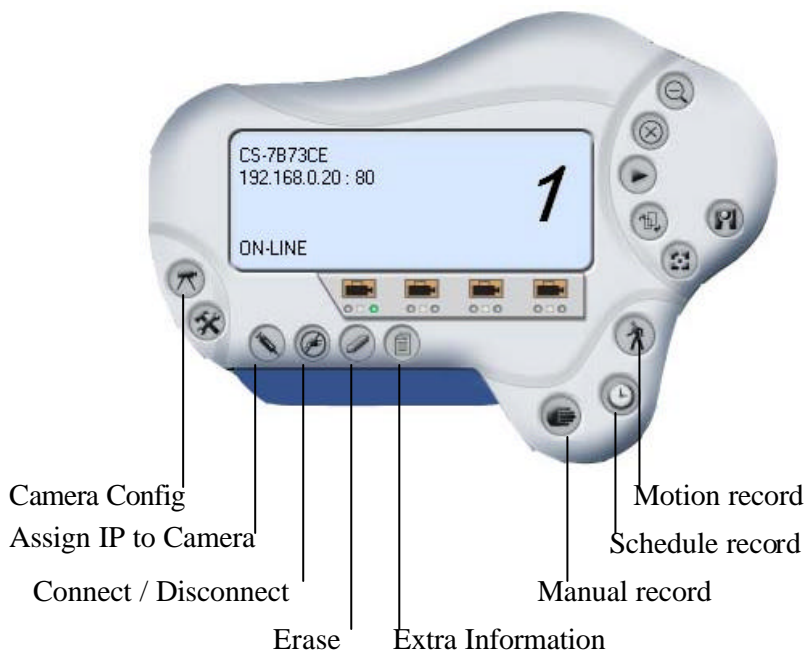

How to Change Camera



Assign IP of New Camera

To change camera, click the “**Assign IP of Camera**” button. An **Assign IP of Camera** dialog box will appear as illustrated below.

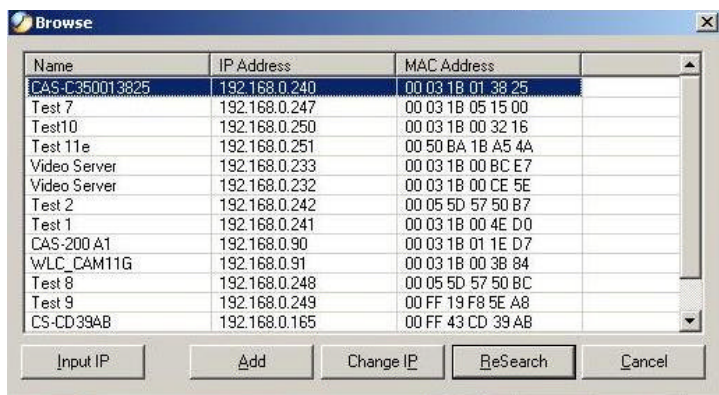

You must select the camera and click the “**Add**” button to add a new camera.

How to Connect / Disconnect the Image

Connect the Image

Click the “**Connect/Disconnect**” button and the preview screen will appear with the video image.



Note:

When a new camera is added, it *IS* connected. You can see the image right away. If you click the “**Connect/ Disconnect**” button, it will be in disconnecting, also, no image showed.

Minimize

Click to minimize the display screen of the Internet Camera.



Maximize

Click to maximize the display screen of the Internet Camera.



Close

Click to close the display screen of the Internet Camera.



Always on top

Click to have the display screen always appear on the top of the window.



Wake up control panel

Click to open the control panel again when it is closed.



Color setting

Click to adjust color of the image.



View list

Click to check the event list of the Internet Camera.



Snapshot

Click to snapshot a picture from the Internet Camera.



Rotate image

Click to rotate the image of the Internet Camera.



Disconnect the Image

Click the **‘Connect / Disconnect’** button, the camera will be disconnected.



How to Delete a Camera

Erase Camera

To delete a camera, you must select the camera to delete from the IPView SE control panel. Then, click the “**Erase Camera**” button.

After deleting the camera, the IPView SE control panel will appear as below.



Extra Information



Extra Information

The screen displays the camera's information.



How to Adjust the Property Setting

System Configure

From the control panel, select the button and the dialog box will appear as shown below.

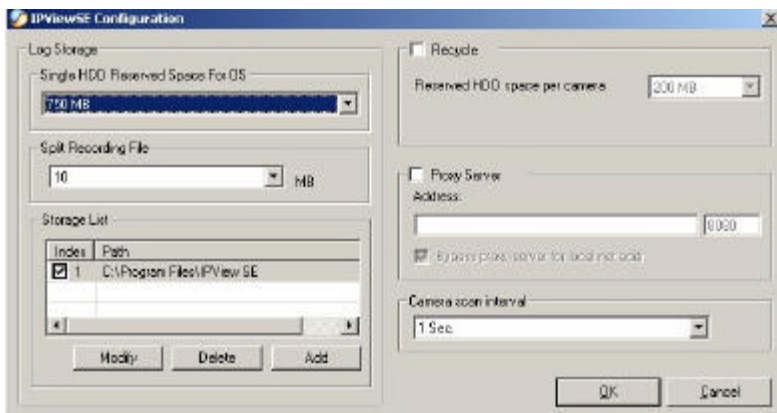

Log Storage:

1. Single HDD Reserve Space
This option permits reserved HDD space from 500 MB to 1000 MB.
2. Split Recording File
From this option, you can adjust the file size for recording the video images (the default setting is 10MB). If the recorded video files reach the file size, video images will be recorded into another file automatically.

By File Size - permits recording by file size from 10 MB to 50 MB.

3. Storage List

This option is used to define the path to save image files.

The software will create a camera name folder as the “Storage List” which is allowed to create up to 16 File Path.

Recycle:

When you enabled this function, it will recycle the HDD space once the disk space is less than the size defined. The size defined can be from 200 MB to 50000 MB.

Proxy Server:

Select this option to enable the Proxy Server support.

Camera Scan Delay:

It allows you to display for each camera one by one. The time interval for each camera can be from 1 Sec. to 20 Sec.



Camera Configure

Click the ‘Camera Config’ button and it will active the Camera Setting, Motion Setting and Update Firmware buttons.

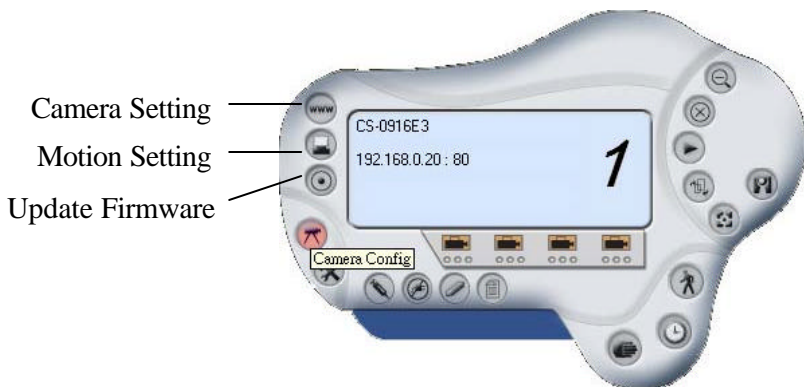

Camera Setting

Please refer to the “*Web Configuration*” section.



Motion Setting

You can adjust the sensitivity level and choose the Invoke Alarm options to work with motion detection function.

Besides the Alarm Beep, Send Email can be enabled when motion detected.

The user can define the time interval to Send E-mail.

The screenshot shows a dialog box titled "Motion Setting" with a close button (X) in the top right corner. It contains the following elements:

- A section labeled "Motion option" containing two checkboxes:
 - Invoke Alarm
 - Send e-Mail
- Below the "Send e-Mail" checkbox is a button labeled "eMail Setting".
- A "Sensitivity Level" section with a horizontal slider ranging from "Low" to "High". The slider is currently positioned approximately one-third of the way from the left.
- At the bottom are two buttons: "Cancel" and "OK".

The screenshot shows a dialog box titled "e-Mail Setting" with a close button (X) in the top right corner. It contains the following elements:

- Mail Server: [Text input field]
- Mail From: [Text input field]
- Mail To: [Text input field]
- Subject: [Text input field]
- User Name: [Text input field]
- Password: [Text input field]
- Interval Time: [Text input field containing "5"] Second
- At the bottom are two buttons: "OK" and "Cancel".

Mail Server: Mail Server IP or name.

Mail From: E-Mail Address of sender.

Mail To: E-Mail Address of receiver.

Subject: Can be any information to high light the message.

User Name: Enter the user name in this field.

Password: Enter the user password in this field to login receiver' s mail server

Interval Time: The time interval to send next E-Mail the unit is by second.



Update Firmware

Enter the **File Path** and click the “**Update**” button, the firmware will be updated automatically.

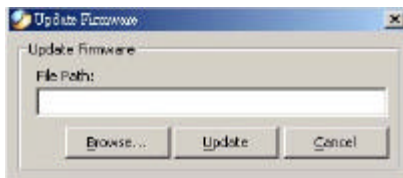

If you are unsure of the File path, you can click the “**Browse**” button, the **Browse** dialog box will appear as illustrated below.



Warning

During firmware update process, please make sure no interruptions will occur as it might possibly cause serious damage to the Internet Camera

How to Adjust the Recording Setting

There are three ways to start recording image - Motion Record, Schedule Record & Manual Record.



Motion Record

This option allows the camera to trigger recording by motion detected. You can adjust the sensitivity level and choose the warning options when motion is detected from motion setting.



Schedule Record

This option allows the camera to trigger recording as schedule defined. The schedule is set by date or week day.



Manual Record

This option allows the camera to trigger recording manually.

APPENDIX

A Frequently Asked Questions

Internet Camera Features

Q: What is an Internet Camera?

A: The Wireless Internet Camera is a standalone system connecting directly to an Ethernet or Fast Ethernet network and supported by the wireless transmission based on the IEEE 802.11b standard. It is different from the conventional PC Camera, the Wireless Internet Camera is an all-in-one system with built-in CPU and web-based solutions providing a low cost solution that can transmit high quality video images for monitoring. The Wireless Internet Camera can be managed remotely, accessed and controlled from any PC/Notebook over the Intranet or Internet via a web browser.

Q: What is the maximum number of users that can be allowed to access the Wireless Internet Camera simultaneously?

A: Maximum number of users that can log onto the Wireless Internet Camera at the same time is 64. Please keep in mind the overall performance of the transmission speed will slow down when many users are logged on.

Q: What algorithm is used to compress the digital image?

A: The Wireless Internet Camera utilizes the JPEG image compression technology providing high quality images for users. JPEG is adopted since it is a standard for image compression and can be applied to various web browser and application software without the need to install extra software.

Q: Can I change the wireless antenna attached to the Wireless Internet Camera?

A: The wireless antenna can be changed for a variety of reasons such as extending the wireless transmission range, however, please consult authorized distributors before attempting as the connectors must be SMA connector type.

Q: What is the wireless transmission range for the Wireless Internet Camera?

A: Generally the wireless distance can go up to 100 meters indoors and up to 300 meters outdoors. The range is limited by the number of walls, ceilings, or other objects that the wireless signals must pass through. Typical ranges vary depends on the types of materials and background Radio Frequency (RF) noise in your home or business and the configuration setting of your network environment.

Internet Camera Installation

Q: Can the Internet Camera be used out-doors?

A: The Wireless Internet Camera is not weatherproof. It needs to be equipped with a weatherproof case to be used outdoors and it is not recommended.

Q: What network cabling is required for the Wireless Internet Camera?

A: The Wireless Internet Camera uses Category 5 UTP cable allowing 10 Base-T and 100 Base-T networking.

Q: Can the Wireless Internet Camera be setup as a PC-cam on the computer?

A: No, the Wireless Internet Camera is an Internet Camera used only on Ethernet and Fast Ethernet network and supported by wireless transmission.

Q: Can the Wireless Internet Camera be connected on the network if it consists of only private IP addresses?

A: The Wireless Internet Camera can be connected to LAN with private IP addresses.

Q: Can the Wireless Internet Camera be installed and work if a firewall exists on the network?

A: If a firewall exists on the network, port 80 is open for ordinary data communication. However, since the Wireless Internet Camera transmits image data, the default port 8481 is also required. Therefore, it is necessary to open port 8481 of the network for remote users to access the Wireless Internet Camera.

B PING Your IP Address

The PING (Packet Internet Groper) command can determine whether a specific IP address is accessible by sending a packet to the specific address and waiting for a reply. It can also provide a very useful tool to confirm if the IP address conflicts with the Wireless Internet Camera over the network.

Follow the step-by-step procedure below to utilize the PING command. However, you must disconnect the Wireless Internet Camera from the network first.

Start a DOS window.

Type ping x.x.x.x, where x.x.x.x is the IP address of the Wireless Internet Camera.

The succeeding replies as illustrated below will provide useful explanation to the cause of the problem with the Wireless Internet Camera IP address.

C Trouble Shooting

Q: I cannot access the Wireless Internet Camera from a web browser.

A1: The possible cause might be the IP Address for the Wireless Internet Camera is already being used by another device. To correct the possible problem, you need to first disconnect the Wireless Internet Camera from the network. Then run the PING utility (follow the instructions in Appendix B - PING Your IP Address).

A2: Another possible reason is the IP Address is located on a different subnet. To fix the problem, run the PING utility (follow the instructions in Appendix B - PING Your IP Address). If the utility returns “no response” or similar, the finding is probably correct, then you should proceed as follows:-

In Windows 95/98/2000 and Windows NT, double check the IP Address of the Wireless Internet Camera is within the same subnet as your workstation.

Click “Start”, “Setting”, “Control Panel”, and the “Network” icon. Select TCP/IP from the “Network” dialog box and from the “TCP/IP Properties” dialog box click “Specify an IP address”.

If the Wireless Internet Camera is situated on a different subnet than your workstation, you will not be able to set the IP address from this workstation. To verify make sure the first 3 sections of the IP address of the Wireless Internet Camera corresponds to the first 3 sections of the workstation. Therefore the IP address of the

Wireless Internet Camera must be set from a workstation on the same subnet.

A3: Other possible problems might be due to the network cable. Try replacing your network cable. Test the network interface of the product by connecting a local computer to the unit, utilizing a standard Crossover (hub to hub) Cable. If the problem is not solved the Wireless Internet Camera might be faulty.

Q: Why does the Power LED not light up constantly?

A: The power supply used might be at fault. Confirm that you are using the provided power supply DC 5V for the Wireless Internet Camera and verify that the power supply is well connected.

Q: Why does the Link LED not light up properly?

A1: There might be a problem with the network cable. To confirm that the cables are working, PING the address of a know device on the network. If the cabling is OK and your network is reachable, you should receive a reply similar to the following (...bytes = 32 time = 2 ms).

A2: The network device utilized by the Wireless Internet Camera is not functioning properly such as hubs or switches. Confirm the power for the devices are well connected and functioning.

A3: The wireless connection might be at fault. In ad-hoc mode make sure the Wireless Internet Camera wireless channel and ESS-ID is set to match the PC/Notebook wireless channel and ESS-ID for direct communication.

Under infrastructure mode make sure the ESS-ID on the PC/Notebook and the Wireless Internet Camera must match with the Access Point's ESS-ID.

Q: Why does the Wireless Internet Camera work locally but not externally?

A1: Might be caused from the firewall protection. Need to check the Internet firewall with your system administrator.

A2: The default router setting might be a possible reason. Need to double check if the configuration of the default router settings is required.

Q: Why does a series of broad vertical white line appears through out the image?

A: A likely issue is that the CMOS sensor becomes overloaded when the light source is too bright such as direct exposure to sunlight or halogen light. You need to reposition the Wireless Internet Camera into a more shaded area immediately as this will damage the CMOS sensor.

Q: There is bad focus on the Wireless Internet Camera, what should be done?

A1: The focus might not be correctly adjusted for the line of sight. You need to adjust the Wireless Internet Camera focus manually as described in Adjust Internet Camera Focus.

A2: There is no adaptor fitted with your C-type lens. If you have previously changed the supplied CS-type lens, you may have unintentionally installed a C-type lens without fitting the adaptor first.

Q: Noisy images occur how can I solve the problem?

A1: The video images might be noisy if the Wireless Internet Camera is used in a very low light environment. To solve this issue you need more lighting.

A2: There might be wireless transmission interference make sure there are no other wireless devices on the network that will affect the wireless transmission.

Q: There is poor image quality, how can I improve the image?

A1: A probable cause might be the incorrect display properties configuration for your desktop. You need to open the Display Properties on your desktop and configure your display to show at least 65' 000 colors for example at least 16-bit.

Note:

Applying only 16 or 256 colors on your computer will produce dithering artifacts in the image.

A2: The configuration on the Wireless Internet Camera image display is incorrect. Through the Web Configuration Image section you need to adjust the image related parameter for improve images such as brightness, contrast, hue and light frequency. Please refer to the Web Configuration section for detail information.

Q: There are no images available through the web browser?

A: The ActiveX might be disabled. If you are viewing the images from Internet Explorer make sure ActiveX has been enabled in the Internet Options menu. Alternatively, you can use the Java Applet for viewing the required images.

D Time Zone Table

(GMT-12:00) Eniwetok, Kwajalein

(GMT-11:00) Midway Island, Samoa

(GMT-10:00) Hawaii

(GMT-09:00) Alaska

(GMT-08:00) Pacific Time (US & Canada); Tijuana

(GMT-07:00) Arizona

(GMT-07:00) Mountain Time (US & Canada)

(GMT-06:00) Central Time (US & Canada)

(GMT-06:00) Mexico City, Tegucigalpa

(GMT-06:00) Saskatchewan

(GMT-05:00) Bogota, Lima, Quito

(GMT-05:00) Eastern Time (US & Canada)

(GMT-05:00) Indiana (East)

(GMT-04:00) Atlantic Time (Canada)

(GMT-04:00) Caracas, La Paz

(GMT-04:00) Santiago

(GMT-03:30) Newfoundland

(GMT-03:00) Brasilia

(GMT-03:00) Buenos Aires, Georgetown

(GMT-02:00) Mid-Atlantic

(GMT-01:00) Azores, Cape Verde Is.

(GMT) Casablanca, Monrovia

(GMT) Greenwich Mean Time : Dublin, Edinburgh, Lisbon, London

(GMT+01:00) Amsterdam, Berlin, Bern, Rome, Stockholm, Vienna

(GMT+01:00) Belgrade, Bratislava, Budapest, Ljubljana, Prague

(GMT+01:00) Brussels, Copenhagen, Madrid, Paris, Vilnius

(GMT+01:00) Sarajevo, Skopje, Sofia, Warsaw, Zagreb

(GMT+02:00) Athens, Istanbul, Minsk

(GMT+02:00) Bucharest

(GMT+02:00) Cairo

(GMT+02:00) Harare, Pretoria
 (GMT+02:00) Helsinki, Riga, Tallinn
 (GMT+02:00) Jerusalem
 (GMT+03:00) Baghdad, Kuwait, Riyadh
 (GMT+03:00) Moscow, St. Petersburg, Volgograd
 (GMT+03:00) Nairobi
 (GMT+03:30) Tehran
 (GMT+04:00) Abu Dhabi, Muscat
 (GMT+04:00) Baku, Tbilisi
 (GMT+04:30) Kabul
 (GMT+05:00) Ekaterinburg
 (GMT+05:00) Islamabad, Karachi, Tashkent
 (GMT+05:30) Bombay, Calcutta, Madras, New Delhi
 (GMT+06:00) Astana, Almaty, Dhaka
 (GMT+06:00) Colombo

 (GMT+07:00) Bangkok, Hanoi, Jakarta
 (GMT+08:00) Beijing, Chongqing, Hong Kong, Urumqi
 (GMT+08:00) Perth
 (GMT+08:00) Singapore
 (GMT+08:00) Taipei
 (GMT+09:00) Osaka, Sapporo, Tokyo
 (GMT+09:00) Seoul
 (GMT+09:00) Yakutsk
 (GMT+09:30) Adelaide
 (GMT+09:30) Darwin
 (GMT+10:00) Brisbane
 (GMT+10:00) Canberra, Melbourne, Sydney
 (GMT+10:00) Guam, Port Moresby
 (GMT+10:00) Hobart
 (GMT+10:00) Vladivostok

 (GMT+08:00) Singapore
 (GMT+08:00) Taipei
 (GMT+09:00) Osaka, Sapporo, Tokyo
 (GMT+09:00) Seoul
 (GMT+09:00) Yakutsk
 (GMT+09:30) Adelaide
 (GMT+09:30) Darwin
 (GMT+10:00) Brisbane
 (GMT+10:00) Canberra, Melbourne, Sydney
 (GMT+10:00) Guam, Port Moresby
 (GMT+10:00) Hobart
 (GMT+10:00) Vladivostok
 (GMT+11:00) Magadan, Solomon Is., New Caledonia
 (GMT+12:00) Auckland, Wellington
 (GMT+12:00) Fiji, Kamchatka, Marshall Is.

E Xplug Control Installation

Installation To Web Server

Important Information

It is highly recommended to install the Xplug Control application to the Web Server for IE 5.0. It must be installed to a Public Domain with Fixed IP address.

1. Installation:

Copy the “xplug.ocx” file to any WEB Server table.

2. Setting (Configuration):

From the Web Configuration menu select “System” and under the “Loading ActiveX From” input web server location

(<http://www.web server location.com/>).

Once the settings are completed, the user now is able to access the Internet Camera from the web browser by selecting the image view – ActiveX mode.

Installation To Local PC

Insert the CD-ROM into the CD-ROM drive to initiate the auto-run program. Once completed, a menu screen will appear as below:

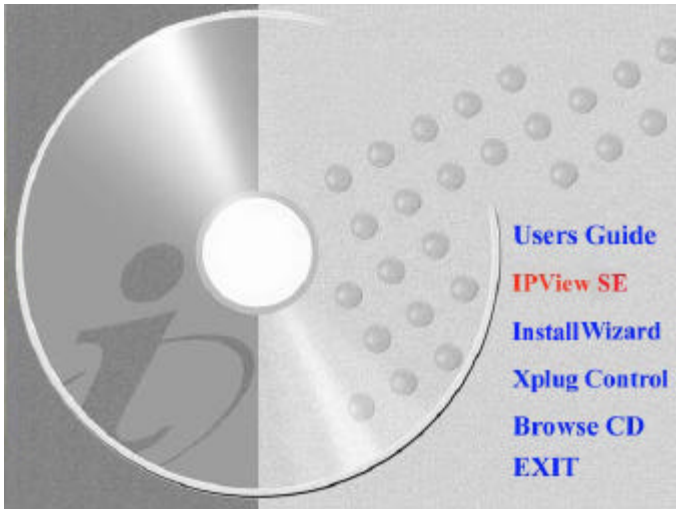

To install Xplug Control, click the **"Xplug Control"** button to activate the installation procedure for the plug-in program.

Once executed, a prompt will appear requesting the input of the desired language selection. Make the desired selection and click **“OK”** to continue.



The Welcome screen will appear. Click the **“Next”** button to proceed with the installation.

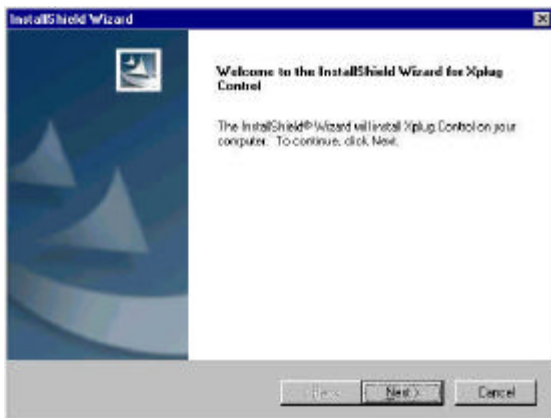

The License Agreement prompt will appear as below. Read the details carefully and click the “Yes” button to continue with the installation procedure.

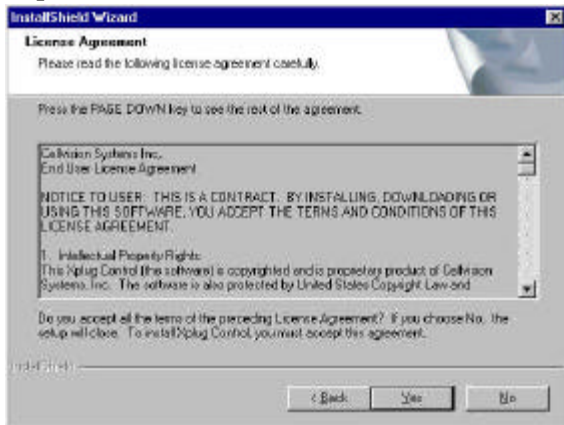

Click the “Finish” button to complete Setup of the Xplug Control Utility program for the Wireless Internet Camera.

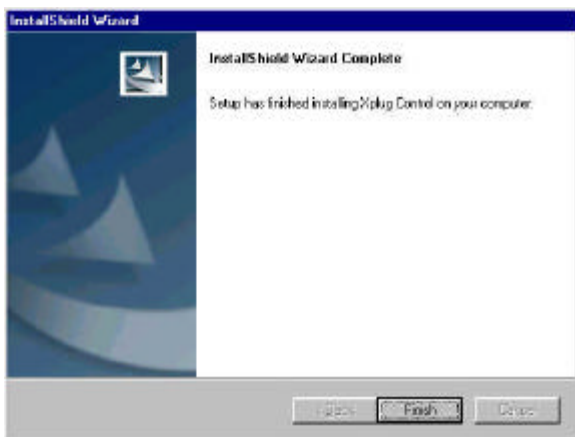

F Adjust Internet Camera Focus

To adjust the focus of the lens, you need to turn the lens slowly in either clockwise or anti-clockwise direction until the desired image appears. DO NOT over turn the lens in either of the directions as it will be out of focus.

Note:

You can further adjust the Wireless Internet Camera's image quality through **System Administration – Image** of Web Configuration. Please refer to Web Configuration section for further details.

Warning

Direct exposure to sunlight may cause permanent damage to the CMOS sensor. Therefore do not expose the Internet Camera's lens directly to sunlight. When operation is required in glaring light environment, it is recommended to use an iris lens.

The Internet Camera is designed for indoor usage and if your application requires prolonged exposure to sunlight, a sun visor is recommended to protect the Internet Camera.

G Specification

Video specification

| | |
|-----------------------|--------------------------------|
| Resolution: | 640 x 480 pixel |
| Sensor: | 1/3" color CMOS sensor |
| Gain control: | Automatic |
| Exposure: | Automatic |
| White Balance: | Automatic |
| Shutter: | Electronics 1/60 ~ 1/15000 sec |
| Minimum Illumination: | 2.5lux@f1.4, 3000K color |
| Focal Length: | 6.0 mm |
| Aperture: | F=1.8 |
| Focus Extent: | 20 cm - 8 |
| Lens mounting: | Fixed board lens |

Image (Video Setting)

| | |
|-----------------------------|---|
| Image compression: | JPEG |
| Frame rate: | 20fps@SIF, 6fps@VGA |
| Compression Rate selection: | Auto |
| Frame rate setting: | 1, 5, 7, 15, 20, auto (depends on the video format) |
| Video resolution: | 320x240, 640x480 |
| Brightness control: | Range 1- 128 |
| Contrast control : | Range 1- 128 |
| Saturation Control: | Yes |

Hardware Interface

| | |
|----------------|---|
| LAN Connector: | One RJ-45 port to connect to 10/100Mbps Ethernet, auto-sensed |
| Wireless LAN: | Built-in 802.11b wireless LAN module (Wi-Fi compliant) |
| LED Indicator: | Power LED (Green) Link LED (Yellow) |

Note:

LED three mode setting can be changed by software. (Normal / Off / Dummy)

Power Supply: DC 5V, switching type
Power Communication: 6.5 Watt (1300mA x 5V)
Antenna Connector: 1 connectors

Communication Support

Communication: 10/100Mbps Ethernet and 802.11b wireless LAN.
Encryption: 64 bit, 128 bit or OFF
Communication protocol: HTTP, FTP, TCP/IP, UDP, ARP, ICMP, BOOTP, RARP, DHCP, PPPoE

Browser Support

System requirement:
CPU: Pentium II, 266 MHz or above
Memory Size: 32 MB (64 MB recommended)
VGA card resolution: 800x600 or above

- Internet Explorer 5.0 or above
- Netscape 6.0 or above

Note:

ActiveX Mode –View Image supports Internet Explorer under Windows OS.

IPViewSE Application

Support OS: Win 98 SE, Win 2000, Win Me, Win XP

System requirement for IPView:
CPU: Pentium III, 450 MHz or above
Memory Size: 128 MB (256 MB recommended)

VGA card resolution: 800x600 or above

Operating environment

Operating temperature: 5°C ~ 50°C
Storage temperature: -25°C ~ 50°C
Humidity: 5% ~ 95% non-condensing

EMI

FCC, CE

HGlossary of Terms

NUMBERS

- 10BASE-T** 10BASE-T is Ethernet over UTP Category III,IV, or V unshielded twisted-pair media.
- 100BASE-TX** The two-pair twisted-media implementation of 100BASE-T is called *100BASE-TX*.
- 802.11b** An IEEE standard for wireless local area networks. It offers transmissions speeds at up to 11 Mbps in the 2.4-GHz band.

A

- Access point** It is the hardware interface between a wireless LAN and a wired LAN. The access point attaches to the wired LAN through an Ethernet connection.
- Applet** Applets are small Java programs that can be embedded in an HTML page. The rule at the moment is that an applet can only make an Internet connection to the computer from that the applet was sent.
- ASCII** American Standard Code For Information Interchange, it is the standard method for encoding characters as 8bit sequences of binary numbers, allowing a maximum of 256 characters.
- ARP** Address Resolution Protocol. ARP is a protocol that resides at the

TCP/IP Internet layer that delivers data on the same network by translating an IP address to a physical address.

AVI Audio Video Interleave, it is a Windows platform audio and video file type, a common format for small movies and videos.

B

BOOTP Bootstrap Protocol is an Internet protocol that can automatically configure a network device in a diskless workstation to give its own IP address.

C

Communication Communication has four components: sender, receiver, message, and medium. In networks, devices and application tasks and processes communicate messages to each other over media. They represent the sender and receivers. The data they send is the message. The cabling or transmission method they use is the medium.

Connection In networking, two devices establish a connection to communicate with each other.

D

DHCP Dynamic Host Configuration Protocol was developed by Microsoft a protocol for assigning dynamic IP addresses to devices on a network. With dynamic addressing, a device can have a different IP address every time it connects to the network. In some systems, the device's IP address can even change while it is still connected. DHCP also supports a mix of static and dynamic IP addresses. This simplifies the task for network administrators

because the software keeps track of IP addresses rather than requiring an administrator to manage the task. This means a new computer can be added to a network without the hassle of manually assigning it a unique IP address. DHCP allows the specification for the service provided by a router, gateway, or other network device that automatically assigns an IP address to any device that requests one

DNS

Domain Name System is an Internet service that translates domain names into IP addresses. Since domain names are alphabetic, they're easier to remember. The Internet however, is really based on IP addresses every time you use a domain name the DNS will translate the name into the corresponding IP address. For example, the domain name *www.network_camera.com* might translate to *192.167.222.8*.

E

Enterprise network

An enterprise network consists of collections of networks connected to each other over a geographically dispersed area. The enterprise network serves the needs of a widely distributed company and operates the company's mission-critical applications.

Ethernet

The most popular LAN communication technology. There are a variety of types of Ethernet, including 10 Mbps (traditional Ethernet), 100 Mbps (Fast Ethernet), and 1,000 Mbps (Gigabit Ethernet). Most Ethernet networks use Category 5 cabling to carry information, in the form of electrical signals, between devices. Ethernet is an implementation of CSMA/CD that operates in a bus or star topology.

F

Fast Ethernet Fast Ethernet, also called 100BASE-T, operates at 10 or 100Mbps per second over UTP, STP, or fiber-optic media.

Firewall Firewall is considered the first line of defense in protecting private information. For better security, data can be encrypted. A system designed to prevent unauthorized access to or from a private network. Firewalls are frequently used to prevent unauthorized Internet users from accessing private networks connected to the Internet, especially Intranets all messages entering or leaving the intranet pass through the firewall, which examines each message and blocks those that do not meet the specified security criteria.

G

Gateway A gateway links computers that use different data formats together.

Group Groups consist of several user machines that have similar characteristics such as being in the same department.

H

HEX Short for hexadecimal refers to the base-16 number system, which consists of 16 unique symbols: the numbers 0 to 9 and the letters A to F. For example, the decimal number 15 is represented as F in the hexadecimal numbering system. The hexadecimal system is useful because it can represent every byte (8 bits) as two consecutive hexadecimal digits. It is easier for humans to read hexadecimal numbers than binary numbers.

I

IEEE Institute of Electrical and Electronic Engineers.

| | |
|-------------------------|---|
| Intranet | This is a private network, inside an organization or company, that uses the same software you will find on the public Internet. The only difference is that an Intranet is used for internal usage only. |
| Internet | The Internet is a globally linked system of computers that are logically connected based on the Internet Protocol (IP). The Internet provides different ways to access private and public information worldwide. |
| Internet address | To participate in Internet communications and on Internet Protocol-based networks, a node must have an Internet address that identifies it to the other nodes. All Internet addresses are IP addresses |
| IP | Internet Protocol is the standard that describes the layout of the basic unit of information on the Internet (the <i>packet</i>) and also details the numerical addressing format used to route the information. Your Internet service provider controls the IP address of any device it connects to the Internet. The IP addresses in your network must conform to IP addressing rules. In smaller LANs, most people will allow the DHCP function of a router or gateway to assign the IP addresses on internal networks. |
| IP address | IP address is a 32-binary digit number that identifies each sender or receiver of information that is sent in packets across the Internet. For example 80.80.80.69 is an IP address, it is the closest thing the Internet has to telephone numbers. When you “call” that number, using any connection methods, you get connected to the computer that “owns” that IP address. |
| ISP | Internet Service Provider, is a company that maintains a network that is linked to the Internet by way of a dedicated communication line. An ISP offers the use of its dedicated communication lines to companies or individuals who can’t afford the high monthly cost for a direct connection. |

J

JAVA

Java is a programming language that is specially designed for writing programs that can be safely downloaded to your computer through the Internet without the fear of viruses. It is an object-oriented multi-thread programming best for creating applets and applications for the Internet, Intranet and other complex, distributed network.

L

LAN

Local Area Network a computer network that spans a relatively small area sharing common resources. Most LANs are confined to a single building or group of buildings.

N

NAT

Network Address Translator generally applied by a router, that makes many different IP addresses on an internal network appear to the Internet as a single address. For routing messages properly within your network, each device requires a unique IP address. But the addresses may not be valid outside your network. NAT solves the problem. When devices within your network request information from the Internet, the requests are forwarded to the Internet under the router's IP address. NAT distributes the responses to the proper IP addresses within your network.

Network

A network consists of a collection of two or more devices, people, or components that communicate with each other over physical or virtual media. The most common types of network are:

LAN – (local area network): Computers are in close distance to one another. They are usually in the same office space, room, or building.

WAN – (wide area network): The computers are in different geographic locations and are connected by telephone lines or radio waves.

NWay Protocol A network protocol that can automatically negotiate the highest possible transmission speed between two devices.

P

PING Packet Internet Groper, a utility used to determine whether a specific IP address is accessible. It functions by sending a packet to the specified address and waits for a reply. It is primarily used to troubleshoot Internet connections.

PPPoE Point-to-Point Protocol over Ethernet. PPPoE is a specification for connecting the users on an Ethernet to the Internet through a common broadband medium, such as DSL or cable modem. All the users over the Ethernet share a common connection.

Protocol Communication on the network is governed by sets of rules called protocols. Protocols provide the guidelines devices use to communicate with each other, and thus they have different functions. Some protocols are responsible for formatting and presenting and presenting data that will be transferred from file server memory to the file server's network adapter. Others are responsible for filtering information between networks and forwarding data to its destination. Still other protocols dictate how data is transferred across the medium, and how servers respond to workstation requests and vice versa. Common network protocols responsible for the presentation and formatting of data for a network operating system are the Internetwork Packet Exchange (IPX) protocol or the Internet Protocol (IP). Protocols that dictate the format of data for transfers over the medium include token-passing and Carrier Sense Multiple Access with Collision Detection (CSMA/CD), implemented as token-ring, ARCNET,

FDDI, or Ethernet. The Router Information Protocol (RIP), a part of the Transmission Control Protocol/Internet Protocol (TCP/IP) suite, forwards packets from one network to another using the same network protocol.

R

- RARP** Reverse Address Resolution Protocol, a TCP/IP protocol that allows a physical address, such as an Ethernet address, to be translated into an IP address.
- RJ-45** RJ-45 connector is used for Ethernet cable connections.
- Router** A router is the network software or hardware entity charged with routing packets between networks.

S

- Server** It is a simple computer that provides resources, such as files or other information.
- SMTP** The Simple Mail Transfer Protocol is used for Internet mail.
- SNMP** Simple Network Management Protocol. SNMP was designed to provide a common foundation for managing network devices.
- Station** In LANs, a station consists of a device that can communicate data on the network. In FDDI, a station includes both physical nodes and addressable logical devices. Workstations, single-attach stations, dual-attach stations, and concentrators are FDDI stations.
- Subnet mask** In TCP/IP, the bits used to create the subnet are called the subnet mask.

T

(TCP/IP)

Transmission Control Protocol/Internet Protocol is a widely used transport protocol that connects diverse computers of various transmission methods. It was developed by the Department of Defense to connect different computer types and led to the development of the Internet.

Transceiver

A transceiver joins two network segments together. Transceivers can also be used to join a segment that uses one medium to a segment that uses a different medium. On a 10BASE-5 network, the transceiver connects the network adapter or other network device to the medium. Transceivers also can be used on 10BASE-2 or 10BASE-T networks to attach devices with AUI ports.

U

UDP

The User Datagram Protocol is a connectionless protocol that resides above IP in the TCP/IP suite

ULP

The upper-layer protocol refers to Application Layer protocols such as FTP,SNMP, and SMTP.

User Name

The USERNAME is the unique name assigned to each person who has access to the LAN.

Utility

It is a program that performs a specific task.

UTP

Unshielded twisted-pair. UTP is a form of cable used by all access methods. It consists of several pairs of wires enclosed in an unshielded sheath.

W

- WAN** Wide-Area Network. A wide-area network consists of groups of interconnected computers that are separated by a wide distance and communicate with each other via common carrier telecommunication techniques.
- Windows** Windows is a graphical user interface for workstations that use DOS.
- Workgroup** A workgroup is a group of users who are physically located together and connected to the same LAN, or a group of users who are scattered throughout an organization but are logically connected by work and are connected to the same network group.
- Workstations** Workstation refers to the intelligent computer on the user's desktop. This computer may be an Intel-based PC, a Macintosh, or a UNIX-based workstation. The workstation is any intelligent device a user works from.